

MICRO GUARD® RCI 510 TELESCOPIC BOOM CRANES

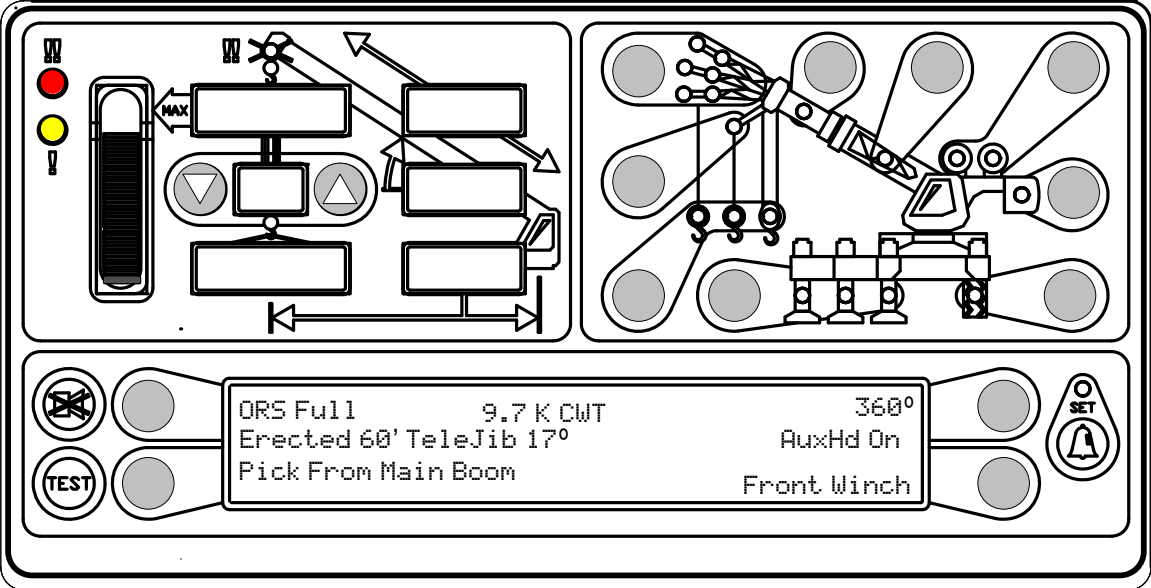

SET UP MANUAL

23,500

44.8

2

62.7

12,300

26.4

OUTLINE OF OPERATION

SYSTEM COMPONENTS

- Microguard® RCI 510 Display Unit
- Microguard® RCI 510 Computer Unit
- Pressure Transducers
- Extension Reel with length and angle sensors
- Anti 2-Block (ATB) switches
- Cables
- Installation/Operator Manuals

The MICROGUARD® RCI 510 System continuously monitors the load and warns of an approach to an overload or Two-Block condition. Crane functions are monitored by means of high accuracy sensors. The system continuously compares the load suspended below the boom head with the crane capacity chart stored in the computer memory. At approach to overload, the system warns by means of audible and visual alarms. The system can be configured to cause function kick-out by sending a signal to function disconnect solenoids.

DISPLAY

The Microguard® RCI 510 System continuously displays:

- Rated Load
- Actual Load
- Bar Graph showing Percentage of Rated Load
- Radius of the Load
- Boom Angle
- Main Boom Length
- Working Area
- Crane Configuration

On-screen messages provide visual warnings of conditions that occur during operation of the system.

BOOM ANGLE SENSOR

The Boom Angle Sensor is a magnetically dampened potentiometer that measures the angle of the boom.

EXTENSION SENSOR

The Extension Sensor measures the length of the boom. It is located inside the Extension Reel cover.

PRESSURE TRANSDUCERS

The pressure transducers measure pressure in the boom hoist cylinder. The signal is then processed to provide a continuous display of the total load suspended below the point of lift.

ANTI TWO BLOCK (A2B)

The Anti Two Block system provides protection by preventing pulling the load block into the head of the boom and causing structural damage to, or breaking the lifting cable. The system, when activated, will prevent movement of any function that could further cause the condition to become unsafe. (Boom Down, Winch Up, Boom Out.)

OPERATOR SETTABLE ALARMS

Operator Settable Alarms provide work area protection zones, warnings for various job site conditions, and alarms for overhead obstructions.

These alarms include:

- Max and Min. Boom Angle
- Max and Min. Boom Extension and Boom Tip Height.
- Work Area and Exclusion Zone Alarms.

Note: Operator Alarms do not cause function lock out to occur.

System Setup

The **Microguard® RCI 510** system contains a setup calibration mode that operates through the system display console. The setup mode provides a means of ensuring that the system sensors are correctly positioned and adjusted following system installation or parts replacement.

This procedure assumes that installation of system components, cabling, and hydraulic connections have been successfully completed and checked.

The setup procedure involves only the sensors mounted within the extension reel on the side of the boom.

It is important that each step of this procedure is properly followed for the system to accurately provide load, rated capacity, warnings, and Kickout functions.



At all times, observe safe practices.

Make sure that crane capacity limitations are understood, and that the crane capacity plate is followed. Do not exceed manufacturer's specified lifting limitations.

Required Tools

For Setup:

Phillips Screwdrivers

Bubble Level – Accurate to 0.1° at level

For Testing:

Inclinometer – accurate to 0.2°

Measuring tape (100 ft) – fiber-type with tenths of feet

Crane Configuration

Before starting the system setup, position the crane on firm and level ground with the outriggers properly extended and set. It is recommended that the crane be configured with no stowed or erected jib (bare boom) and reeved with a single part-of-line.

Entering Setup Mode

The display will step through each setup operation, as required by the user. During the setup procedure, the display console should be placed in a position that allows easy viewing while adjustments are being made within the boom extension reel, and allows for operation of the display buttons. The setup mode is activated by the following procedure:

1. Press the Test and Operator Alarm Buttons simultaneously and the Microguard RCI 510 console will request a security code be entered in order to get into the calibration routine. You will then have 5 seconds to enter the proper button pushing sequence, and when this is done, the information screen will show **“Entering Calibration Mode”**.

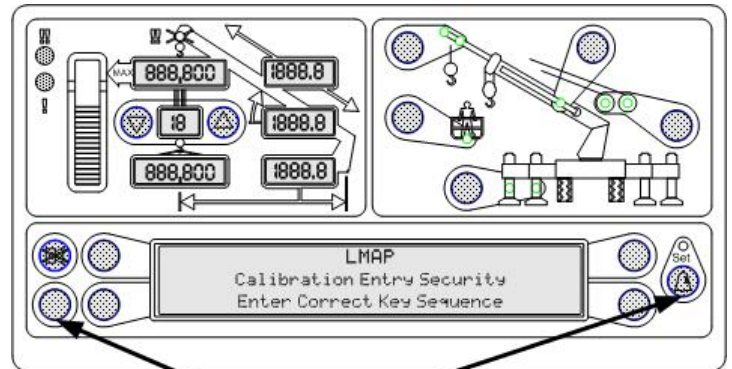

Press and hold the Test and Alarm Buttons Simultaneously

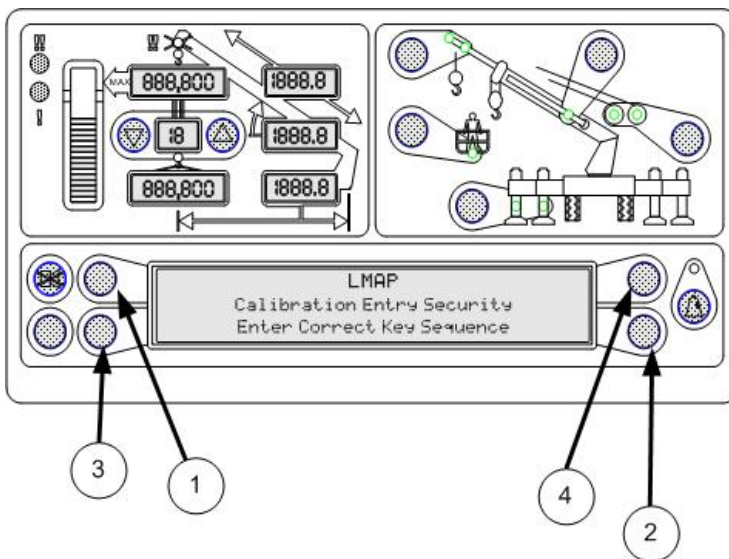

When the system asks for the Calibration Entry Security, the following entry must be made within 5 seconds in order to be allowed access to the calibration routines.

1. **Upper Left**
2. **Lower Right**
3. **Lower Left**
4. **Upper Right**

If this entry is not completed within 5 seconds, the system will revert to a “Normal Operating Screen”. The first screen to appear after the entry into the calibration mode will be the error code screen. This screen will have error codes lined up across the bottom of the information screen like the illustration on the next page.

Checking for Error Codes

All error codes should be "0"s, and the Duty Chip number should appear, as well as the serial number of the computer system installed on the unit. The button adjacent to "Exit" will take you back to the main menu.

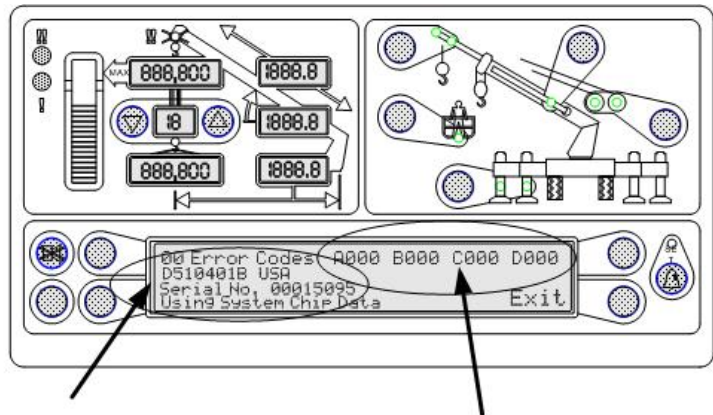

Duty Chip Number
Serial# of Computer

Error Codes

Why Zero and Span?

In order for the computer to accurately measure length and angle, we must insert accurate start and stop points for it to measure from and to. To accomplish it the Microguard® RCI 510 display uses a very simple menu system for the calibration. The Menu screen is arranged so that the 4 keys surrounding the information screen can be used as function select buttons.

The menus used in the setup calibration are as follows:

- **Menu 2- Zero Sensors**
- **Menu 3- Span Sensors**
- **Menu 4- Swing Pot Calibration**

The menu in use is noted at the top of the information screen. You must use the menu up and menu down function to first locate the menu number and the sensor number to assure that you are calibrating the proper sensor. Sensors for the system are as follows:

- **Sensor 2 = Boom Extension**
- **Sensor 3 = Boom Angle**

In order to calibrate the system, the unit should be set up on firm level ground and the outriggers at their fully extended position. It is acceptable for the Side-Folding Jib to be in place, as long as it is noted in the display setup as a stowed jib. For the first steps of the calibration procedure set the boom at 0° (perfectly level), using a digital level that is accurate within .1° degree. The boom should be fully retracted.

Zero for Extension

Start the unit and put the console into the calibration mode and menu up until your "02 Zero Sensors" menu is on the right side of the information window. Press the upper right button and the "Zero No. 2 = XX" will appear as in the illustration at the right.

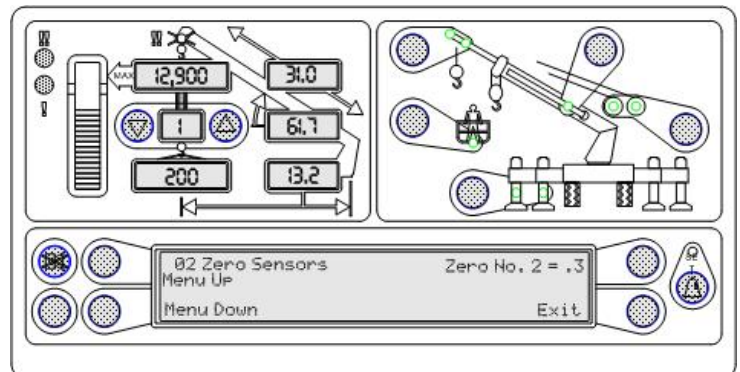

Remove the cover from the reeling drum and locate the extension sensor. Rotate the Extension Sensor gear Clockwise, until the clutch clicks and then rotate to the left until the number adjacent to the “Zero No. 2” in the information screen equals “0” as in the picture below.

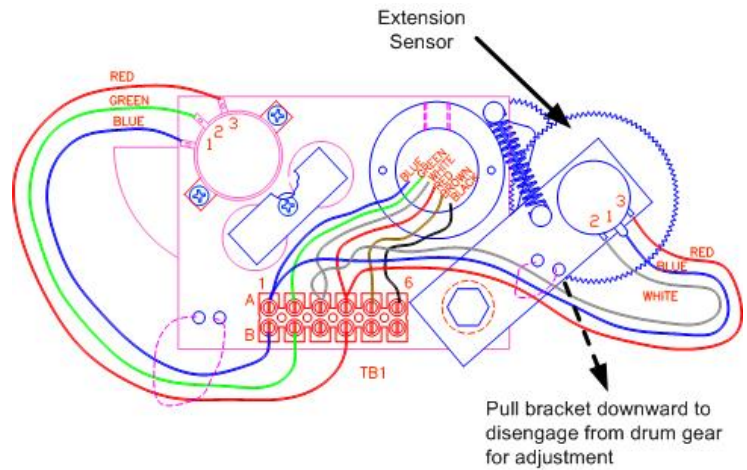

Press the upper right button adjacent to “Zero NO. 2” and the display should verify that you want to calibrate the extension “0”. (YES! CALIBRATE!) Pressing the button a second time will cause the number to the right of “Zero No. 2” to go to “0”, and the extension zero is finished. The retracted boom length should appear in the boom length window as in the picture at the right.

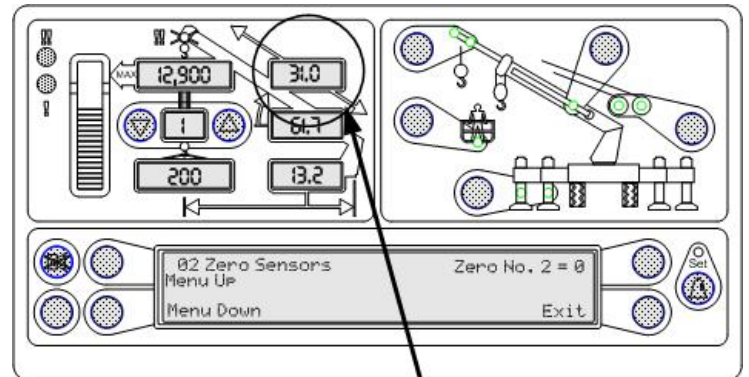

Setting Zero for Boom Angle

Press the Menu Up Button and the display will scroll up to “Zero No. 3”, which is the Angle Sensor. With the boom still setting at the 0° level, we must next set the zero calibration in the display. The display should look like the illustration to the right.

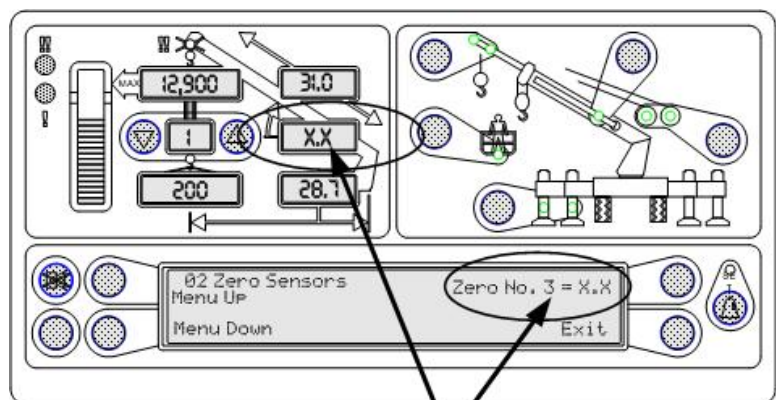

Adjusting the displayed “0” to match the actual “0” on the leveling tool.

Using a digital volt meter, check the voltage reading between the blue wire on the terminal (negative) and the Green Wire (positive). The voltage should read between .470 and .475 Volt. If this reading is not within the tolerance, you may have to adjust the angle potentiometer to get the correct voltage reading.

The potentiometer may be rotated in its mounting by loosening the two attaching screws just enough to allow rotation of the pot. When the “0” is reached on the display, the screws must be securely re-tightened.

Note: This device is very sensitive, so it should be rechecked after retightening to make sure the reading didn't move.

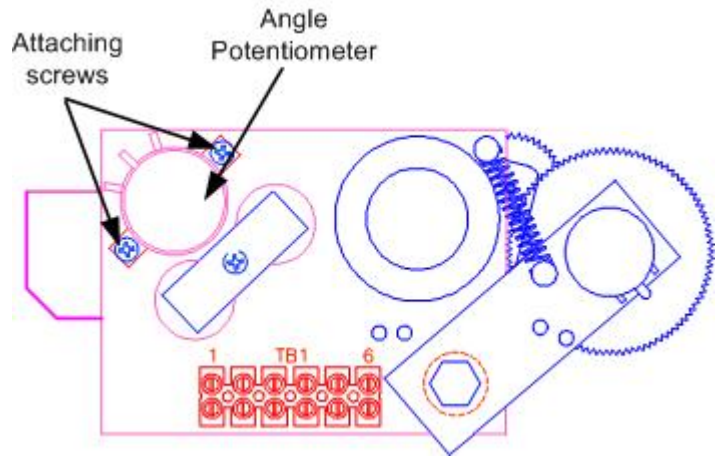

Once the level and the display agree, you may proceed with the zeroing process in the calibration screen on the Microguard® RCI 510 display.

Press the upper right button adjacent to “Zero NO. 3” and the display should verify that you want to calibrate the boom angle “0”. (YES! CALIBRATE!) Pressing the button a second time will cause the number to the right of “Zero No. 3” to go to “0”, and the extension zero is finished. The retracted boom length should appear in the boom length window as in the picture at the right.

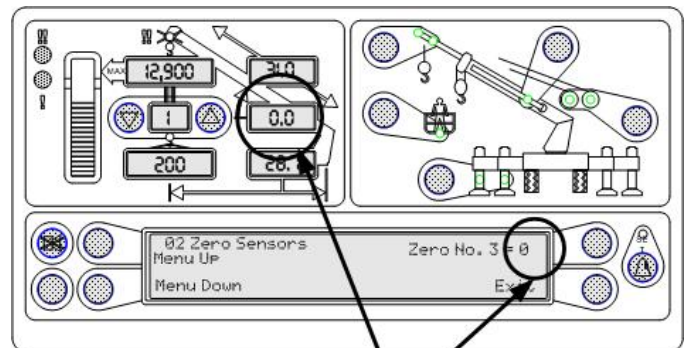

These two windows should agree on the “0”.

With this part of the procedure completed, you should be able to move on to the “Spanning Routine”, which is menu No. 3 on your display. Press the button next to exit in the zero spanning routing. Using the Menu Up and Menu Down buttons on the display, press menu up until the display looks like the screen at the right. Pressing the button by the 03 Span Sensors menu, will let you enter the screen for spanning operations. The screen should then appear like the screen on the following page.

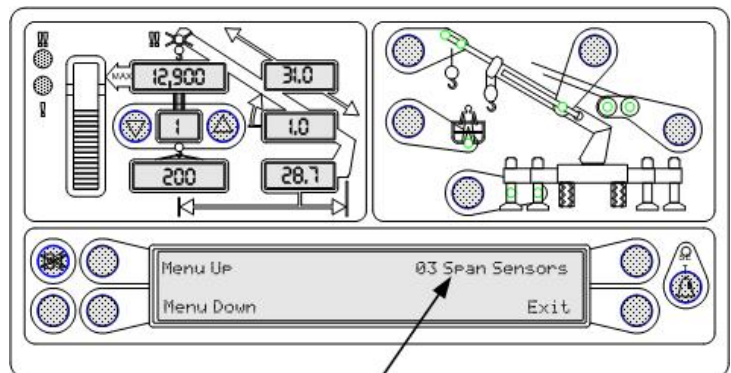

Entering Span Routine



The functions of spanning the boom, includes actions that necessitate full boom extension, so you must maneuver the boom into a boom angle that will allow you to *safely* extend the boom to the fullest length. (**Usually above 65°**)

You must take precautions to avoid overhead power lines and any other obstructions that may exist.

Remember to have the proper numbers to enter for the “Extension Span” before starting the spanning routine. The retracted boom length should already be showing in the boom extension window after the extension function has been “zeroed”. The span measurement, if not available must be measured as follows:

With the boom fully extended, measure from the centerline of the boom hinge pin to the centerline of the boom head sheave. This measurement should then be deducted from the retracted length shown in the boom length window.

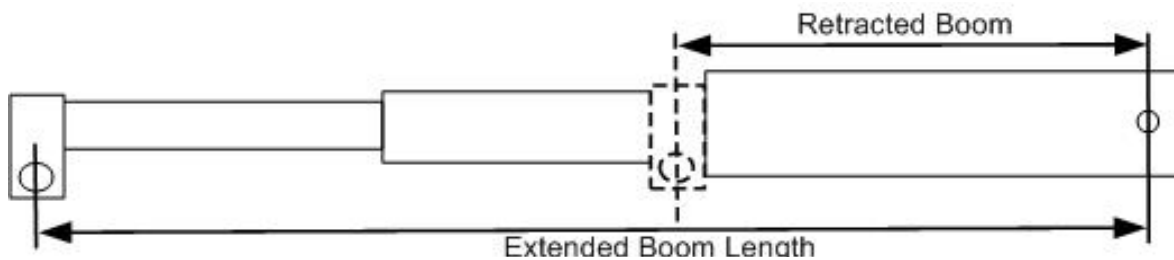

$$\text{EXTENDED BOOM LENGTH} - \text{RETRACTED BOOM} = \text{BOOM SPAN}$$

Entering a Span

After the boom span “number” has been determined, you may raise the boom and fully extend and proceed to the “Span No. 2” window on the console. Pressing the upper right button on the information window will produce a screen that looks like the screen at the right. Pressing the upper right key will produce a message: “Yes Calibrate”. When the button is pressed a second time the unit will again change screens and give you an entry screen for the Extension Span as shown on the following page.

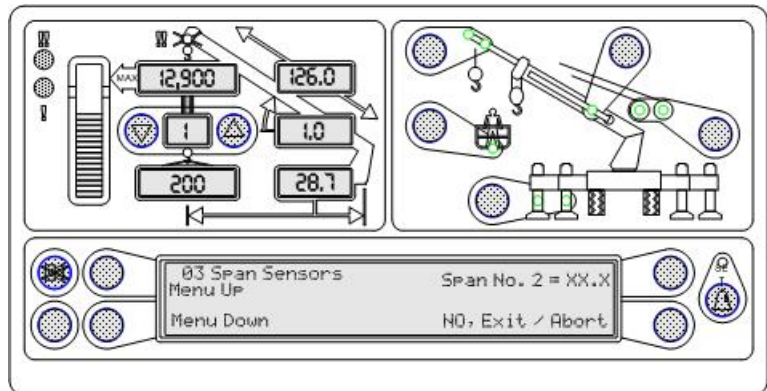

The Entry Screen

The entry screen for both Extension and Angle span look identical. So you need to be careful of which function you are working with.

The "Span Entry Window" will look like the example at the right. Note a pair of brackets ([]) at the upper right hand side of the screen is the location where the numbers to be entered will be temporarily stored. The numbers in the bracket are entered into the bracket using the left upper key. You must always enter decimal points in the numbers, even if the number is an even number (like 75.0). You would still add the decimal.

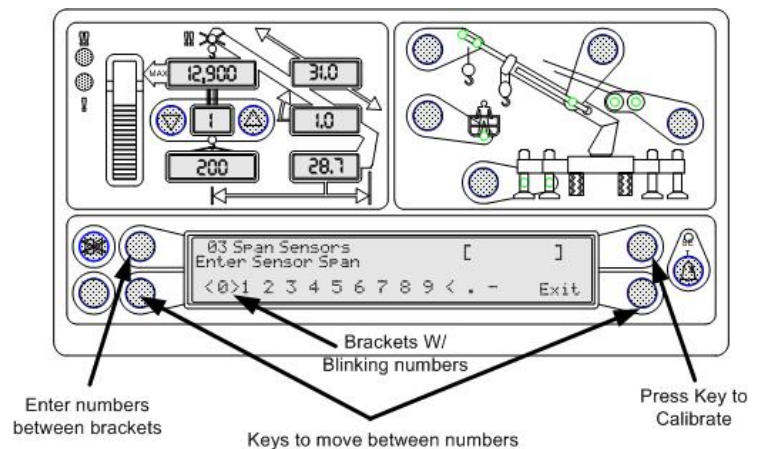

The two lower keys are used to scroll between the number values shown on the screen. (Note: The number blinking between the < > brackets is the number that will be entered between the ([]) in the upper right portion of the screen) When the desired numbers are entered between the ([]), and the upper right key is pressed to calibrate, the proper span will be installed into the computers memory, and the correct extended boom length will then appear in the boom length window. As shown in the example below:

It is advisable to retract the boom and recheck the extension "0", and then re-extend the boom to double check the extended number again.

With this accomplished, press the Menu Up button again and the screen will move to "Span No. 3 = XX.X".

The same instruction as above applies for the number entries for the boom angle span. The only difference is that this time you will be entering the numbers in degrees and 1/10's of a degree, and the information will be taken from the reading on the digital level on the boom.

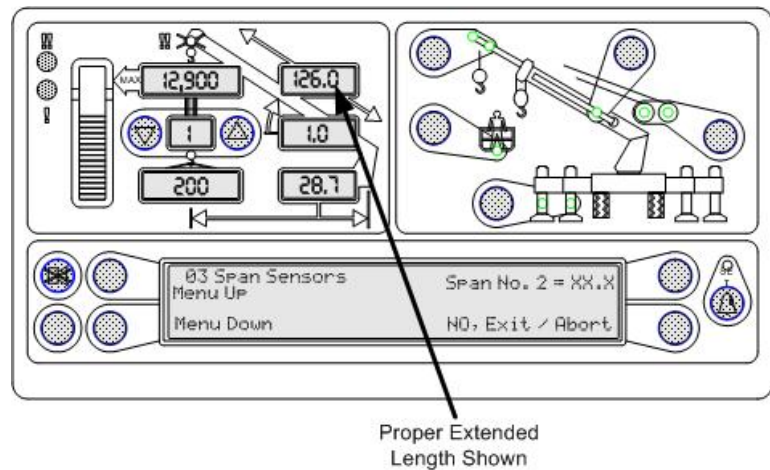

With the boom at 65° or above read the level and enter the exact angle reading from the level. When the information is entered into the ([]) brackets, press the upper right hand button to calibrate the input. The boom angle window on the display should agree with the level. Lower the boom to another angle (say 45°) and be sure that the reading still agrees with the level within +/- .2 of a degree. At this point, it is an excellent idea to manually check the radius and compare the actual radius with radius displayed on the MICROGUARD® RCI 510 console. This should agree within .5 of a foot. (Or approx. 6").

Before load testing the unit, we must complete one more step in the calibration procedure and that is to calibrate the swing pot, so the computer can recognize where the upper turret structure is in relation to the Sub Frame structure.

The boom on the unit should be fully retracted and the boom centered and stowed in the boom rest. This will become the "0°", or stowed position in the boom swing arc.

In order to calibrate zero you will need to put the MICROGUARD® RCI 510 console back into the calibration mode, and menu up until you reach "**Menu 04 Swing Potentiometer**".

Press the upper right key around the information screen and the display will look as show in the example the below.

With the boom stowed as per the instructions above, the display should be showing either 360° or 1°. With this set, pick the boom up out of the boom rest and rotate a few degrees to the right. The numbers should start counting upward, 1, 2, 3, etc.. If this does not happen, press the Menu Up button and the screen should change to read Direction = (+ or -). By pressing the upper right hand button the reading should change to the opposite direction, and the swing zero is complete. Press the button adjacent to Exit on the screen and you will return to the calibration screen menu.

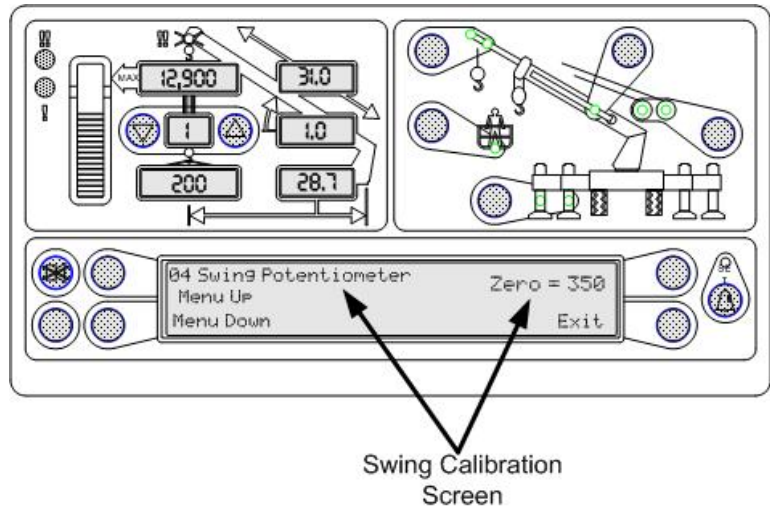

Setting the Rope Limit Option

When the crane has the option of different cables with different rope limits, it becomes necessary to reset the cable limit to facilitate this. The final step in the initial or setup calibration to setting the cable size that is in use on this unit.

To set this important factor, press the Menu Up button until "**Menu 10 Rope Limit**" is reached, and press the button on the upper right side of the information screen.

This will move the screen to the **CURRENT ROPE LIMIT = XX.X** as per the example at the right. In order to change the rope limit as needed, the upper right hand button will be pressed once and the screen will change to reflect the new Cable rope limit. Press the exit button to return to the calibration menu and once more to reset and the system will go through the self-test mode and come up in the "Normal Mode".

