

GREER COMPANY

Crane Systems

**MICROGUARD® RCI-510
RATED CAPACITY LIMITER SYSTEM**

**TROUBLESHOOTING
MANUAL**



The Greer Company

The Greer Company is dedicated to the design and manufacture of electronic parts created to aid in crane operation and in the protection of crane operators and associated personnel. The following manual has been developed to assist in helping Service Personnel to understand, locate, and identify problems that may arise during the operation of the MicroGuard[®] RCI-510 Rated Capacity Limiter System. Persons using this Manual must be familiar with this System and with Electrical Servicing. Use of calibration routines without consultation with the Greer Company invalidates the warranty.

TABLE OF CONTENTS

MICROGUARD[®] RCI-510

RATED CAPACITY LIMITER SYSTEM

TROUBLESHOOTING MANUAL

INTRODUCTION

SERVICE DEDICATION..... INSIDE FRONT COVER

WHERE TO GO FOR HELP4

SECTION 1

OVERVIEW & PREPARATION.....5

SECTION 2

PROBLEM FINDER 6

SECTION 3

COMPUTER UNIT..... 19

SECTION 4

DISPLAY CONSOLE..... 31

SECTION 5

REMOTE BAR GRAPH 35

SECTION 6

EXTENSION REEL 38

SECTION 7

ANTI TWO-BLOCK FUNCTION..... 57

SECTION 8

POWER, KICKOUT & BOOM MODE OUTPUTS 62

SECTION 9

SWING SENSOR..... 64

WHERE TO GO FOR HELP

When field repairs cannot be made without replacement of a part, or when troubleshooting advice is needed, one of the following support numbers should be called:

TEREX

Waverly, Iowa

Telephone: (319) 352-3920

FAX: (319) 352-9378

Greer Company

Service: Santa Ana, CA

Telephone: (714) 259-9702

FAX: (714) 259-7626

Information provided to support personnel must be accurate and complete. Please follow the Problem Finder guidelines in Section 2. Have your crane Model Number and Serial Number ready. Carefully describe the problem, noting any unusual System responses that may help us to quickly and effectively solve your problem.

SECTION 1 - OVERVIEW & PREPARATION

This Troubleshooting Manual for the MicroGuard® RCI-510 Rated Capacity Limiter System, manufactured by the Greer Company provides information and methods for isolating problems that may arise during operation of the System. Some of these problems can be corrected in the field. Other problems may require replacement of parts or a return of a part to the factory for servicing. Service personnel should have prior training and experience in the procedure for operation and setup of this System.

The procedures in this manual, where possible, are based on crane operation and function. A basic tool kit consisting of wrenches and screwdrivers (flat and Phillips' blades) will be required to remove covers and units for inspection. A digital multimeter (DMM) may be required. The DMM must be capable of measuring DC voltage with a range of 0 volts to ± 50 volts and resolution of 0.1 volts. Resistance range is 0 ohms to 2 megohms. Low cost analog meters are not appropriate since the input impedance of these meters can give false readings.

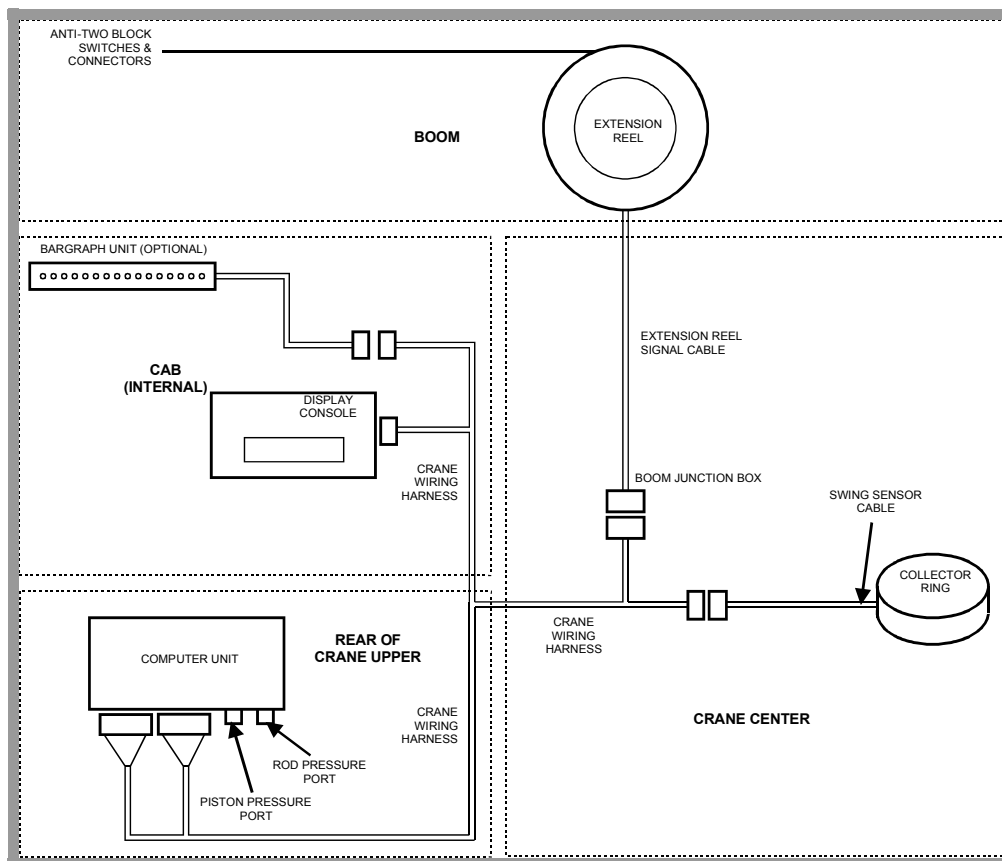

FIGURE 1.1 SYSTEM SCHEMATIC OVERVIEW

SECTION 2 - PROBLEM FINDER

This PROBLEM FINDER section is designed to aid in determining the location and type of problem experienced. It is important to follow the recommendations within this section before contacting the Greer Company.

2.1 SYSTEM SELF-TEST 7

2.2 DISPLAY CONSOLE PROBLEMS 8

2.3 FAULT REPORTING AND FAULT CODES 9-14

 2.3.1 GROUP "A" FAULT CODES 10-11

 2.3.2 GROUP "B" FAULT CODES 12

 2.3.3 GROUP "C" FAULT CODES 13

 2.3.4 GROUP "D" FAULT CODES 14

2.4 "NO FAULT CODE" PROBLEMS 15-17

 2.4.1 ANTI TWO-BLOCK ALARM 15

 2.4.2 DISPLAYED LOAD OR RADIUS ERRORS 16-17

2.1 SYSTEM SELF-TEST

When the power is turned on or when the "TEST" button is pressed during operation, the computer and operator's display console perform a "SELF-TEST," which, as far as is possible, verifies that the computer, display console, cables, and all remote sensors are working properly.

During SELF-TEST, all display functions are activated, allowing the operator to check whether or not all indicators are functional.

NOTE: It is important that the indications shown during the SELF-TEST are recognized and fully understood by the operator in order to aid in correctly determining computer and display communication problems.

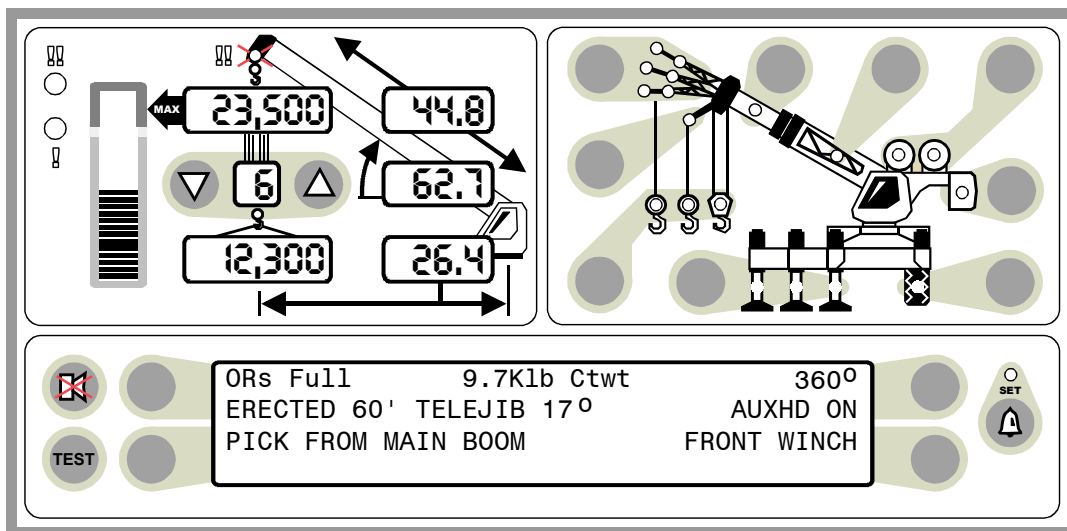

FIGURE 2.1 THE DISPLAY CONSOLE

For six seconds following "power on" or activation of the TEST button (T), the display will show the following indications:

- All display segments of the bar graph display (B) will be black (ON).
- All display segments of the load, angle, radius, length, and rated capacity windows will be black (ON), showing "188.8" or "888,800" for load and capacity.
- All green configuration lamps will be illuminated.
- The red LED indicators for overload and Anti Two-Block will be illuminated.
- The yellow LED indicator for pre-warning will be illuminated.
- The audible alarm will sound in the crane cab.
- The display will now show the crane model/chart number and the units of measurement along with the message: "SELF-TEST IN PROGRESS."
- The display will then freeze with the message:
"READ/ UNDERSTAND THE FOLLOWING ASMA MANUAL. ANST/ANSI B30-5"



OSHA REGULATIONS, OPERATOR'S MANUAL."

- The display segments will be set to (----) and the red and amber and ATB lamps will be on. All green configuration lamps will be illuminated.

IF ANY OF THE ABOVE INDICATIONS DO NOT OCCUR, CONTINUE TO SECTION 2.2 DISPLAY CONSOLE PROBLEMS.

2.2 DISPLAY CONSOLE PROBLEMS

DISPLAY CONSOLE PROBLEMS are difficult to isolate because of the interaction between the display console and the computer unit. Failure of either unit, or interconnection of the two units, causes malfunction of display console indications. No "FAULT" diagnoses of other system problems can be carried out without the proper function of the display console and it's communication with the computer unit.

To solve problems using display console indications, carefully observe the display console at "power

PROBLEM	ACTION
There are no display console indications at all when power is turned on. All displays remain blank and no lights are illuminated.	Refer to SECTION 3.3.
The load, angle, radius, length, and rated capacity display windows do not show "188.8" or the bar graph display window has missing black segments during the self-test.	Replace display console.
The red or yellow indicator lights do not illuminate during self-test.	Replace display console.
The display console does not do the self-test. No words or logical numbers ever appear after power is turned on. The displays look jumbled, with lots of missing segments.	Replace display console.
The display console lights are lit. Load, angle, radius, length and rated capacity show "188.8" or 888,800 for load and capacity, but the display window shows only a message: "Bad communications with main computer."	Display console is OK. Check connectors at rear of display console. Refer to SECTION 3.4.

2.3 FAULT REPORTING AND FAULT CODES

SYSTEM FAULT CODES provide one of the most important ways to quickly locate and assess problems in the MicroGuard® System. Please review this section carefully.

Each time the system is turned on, it goes through a self-testing process lasting six seconds that automatically detects most faults in the system. During normal operation, a self-test can be initiated at any time by pressing the TEST button on the display console.

Many fault conditions are detected without a system self-test.

Faults detected in the system during the self-test, are indicated on the display console in the following ways:

- The RED OVERLOAD LAMP will illuminate.
- The AUDIBLE ALARM will sound.
- "WARNING SYSTEM FAULT!" will be displayed at the bottom of the text window.

Fault codes may be displayed on the display console. To view the codes, press and hold the TEST button and wait for the system to complete the self-test. Do not release the TEST button. Fault codes will now be displayed at the bottom of the text window for as long as the TEST button is held down.



FAULTS A000 B0 C00 D00

FIGURE 2.2 FAULT CODE DISPLAY SHOWN IN LOWER PORTION OF TEXT DISPLAY WINDOW

There are four groups of FAULT CODES: A,B,C & D. The function of these groups and a complete listing of each code is provided on the following pages.

NOTE

ALWAYS INVESTIGATE FAULTS IN THE "B" AND "C" GROUPS BEFORE CONTINUING WITH "A" AND FINALLY "D" GROUP FAULTS.

2.3.1 GROUP “A” FAULT CODES

GROUP “A” FAULT CODES REPRESENT FAULTS DETECTED FOR ANALOG SENSORS.

NOTE: CHECK AND REPAIR “B” AND “C” GROUP FAULTS **BEFORE** PROCEEDING WITH GROUP “A” FAULT FINDING SENSORS,

The following chart details all the available codes in the left column and the actions to take in the right column.

FAULT CODE	Swing Sensor	Boom Angle Sensor	Extension Sensor	Tdx 1 Rod Pressure	Tdx 0 Piston Pressure	ACTION
000	No Fault Found					NONE
001					X	Replace computer
002				X		
003				X	X	
004			X			Follow SECTION 6.4
005			X		X	Replace computer
006			X	X		
007			X	X	X	
008		X				Follow SECTIONS 6.6 through 6.8
009		X			X	Replace computer
010		X		X		
011		X		X	X	
012		X	X			Follow SECTION 6.3
013		X	X		X	Replace computer
014		X	X	X		
015		X	X	X	X	

2.3.1 GROUP “A” FAULT CODES continued

FAULT CODE	Swing Sensor	Boom Angle Sensor	Extension Sensor	Tdx 1 Rod Pressure	Tdx 0 Piston Pressure	ACTION
016	X					Follow SECTION 9
017	X				X	Replace computer
018	X			X		
019	X			X	X	
020	X		X			Follow SECTIONS 6.3, 6.4 & 9
021	X		X		X	Replace computer
022	X		X	X		
023	X		X	X	X	
024	X	X				Follow SECTIONS 6.7, 6.8 & 9
025	X	X			X	Replace computer
026	X	X		X		
027	X	X		X	X	
028	X	X	X			Follow SECTIONS 6.3, 6.4, 6.7, 6.8 & 9
029	X	X	X		X	Replace computer
030	X	X	X	X		
031	X	X	X	X	X	Follow SECTIONS 6.3, 6.4, 6.7, 6.8 & 9
032 & Higher	<p style="text-align: center;">Internal Temperature Sensor Fault</p> <p style="text-align: center;">Replace Computer Unit</p>					

2.3.2 GROUP “B” FAULT CODES

GROUP “B” FAULT CODES REPRESENT FAULTS DETECTED FOR INTERNAL ANALOG FUNCTIONS AND POWER FEEDS TO THE FUNCTION KICKOUT AND ANTI-TWO BLOCK SWITCHES.

The following chart details all of the available codes in the left column and the actions to take in the right column.

FAULT CODE	FKO POWER FEED	A2B POWER FEED	DISPLAY CONSOLE	ADC 2 INTERNAL FAULT	ADC 1 INTERNAL FAULT	ACTION
000	No Fault Found					NONE
001					X	Replace computer
002				X		
003				X	X	
004			X			
005			X		X	
006			X	X		
007			X	X	X	
008		X				See SECTION 7
009		X			X	Replace computer
010		X		X		
011		X		X	X	
012		X	X			
013		X	X		X	
014		X	X	X		
015		X	X	X	X	
016	X					Check crane circuit breakers, then See SECTION 3.5.1
017	X				X	Replace computer
018	X			X		
019	X			X	X	
020	X		X			
021	X		X		X	
022	X		X	X		
023	X		X	X	X	
024	X	X				Check crane circuit breakers, then See SECTION 3.5.1
025	X	X			X	Replace computer
026	X	X		X		
027	X	X		X	X	
028	X	X	X			
029	X	X	X		X	
030	X	X	X	X		
031	X	X	X	X	X	



2.3.3 GROUP “C” FAULT CODES

GROUP “C” FAULT CODES REPRESENT FAULTS DETECTED FOR INTERNAL COMPUTER MEMORIES.

The following chart details all the available codes in the left column and the actions to take in the right column.

FAULT CODE	SERIAL EEPROM	CRANE DATA	RAM	DUTY DATA	PROGRAM	ACTION
000	No Fault Found					NONE
001					X	Replace system chip Follow SECTION 3.5.2
002				X		
003				X	X	
004			X			Replace computer
005			X		X	Replace system chip Follow SECTION 3.5.2
006			X	X		
007			X	X	X	
008		X				Reset crane data
009		X			X	Replace system chip Follow SECTION 3.5.2
010		X		X		
011		X		X	X	
012		X	X			Replace computer
013		X	X		X	Replace system chip Follow SECTION 3.5.2
014		X	X	X		
015		X	X	X	X	
016	X					Reselect crane setup/ configuration
017	X				X	Replace system chip Follow SECTION 3.5.2
018	X			X		
019	X			X	X	
020	X		X			Replace computer
021	X		X		X	Replace system chip Follow SECTION 3.5.2
022	X		X	X		
023	X		X	X	X	
024	X	X				Reselect crane setup/ configuration Reset crane data
025	X	X			X	Replace system chip Follow SECTION 3.5.2
026	X	X		X		
027	X	X		X	X	
028	X	X	X			Replace computer
029	X	X	X		X	
030	X	X	X	X		
031	X	X	X	X	X	

2.3.4 GROUP “D” FAULT CODES

GROUP “D” FAULT CODES REPRESENT FAULTS DETECTED FOR CAPACITY CHART SELECTION.

The following chart details all the available codes in the left column and the actions to take in the right column.

FAULT CODE	WRONG SWING AREA	WRONG BOOM LENGTH	CHART NOT FOUND	ACTION
000	No Fault Found			NONE
001			X	Re-select CRANE SETUP. Check other sensor faults first.
002		X		Boom length is out of range for selected chart. Check crane setup, boom length and extension
003		X	X	Re-select CRANE SETUP. Check other sensor faults first.
004	X			Swing to correct working area to select chart. Check swing sensor zero position. Follow SECTION 9.5
005	X		X	Swing to correct working area to select chart. Check swing sensor zero position. Follow SECTION 9.5
006	X	X		Re-select CRANE SETUP. Check other sensor faults first.
007	X	X	X	Re-select CRANE SETUP. Check other sensor faults first.

2.4 “NO FAULT CODE” PROBLEMS

THIS SECTION ADDRESSES THOSE PROBLEMS THAT MAY OCCUR AND ARE NOT REPORTED BY THE COMPUTER FAULT CODE SYSTEM.

2.4.1 ANTI TWO-BLOCK ALARM (A2B)

This section gives direction to fault diagnosis of A2B alarm problems. For detailed information, schematic, and voltages, refer to SECTION 7 - ANTI TWO-BLOCK FUNCTION.

PROBLEM:

- The Anti Two-Block alarm is continuously **ON**. Operating the switch at the boom head does not deactivate the alarm.

This problem suggests an open circuit between the computer A2B input and the A2B switch(es), or an open circuit between the computer A2B feed and the A2B switch(es)

1. Check extension reel-off cable for damage.
2. Make sure that the Two-Block switches are correctly connected.
3. Check the slip-ring and wiring inside the extension reel.
4. Check the signal cable from the extension reel to the computer. Check connectors.

PROBLEM:

- The Anti Two-Block alarm is continuously OFF (safe). De-operating the switch at the boom head, by lifting the A2B weight does not activate the alarm.

This problem suggests a short circuit between the computer A2B input and the computer A2B feed somewhere between the computer and the A2B switch(es).

1. Check extension reel-off cable for damage.
2. Make sure that the Two-Block switches are correctly connected.
3. Check the slip-ring and wiring inside the extension reel.
4. Check the signal cable from the reel to the computer. Check connectors.

2.4.2 DISPLAYED LOAD OR RADIUS ERRORS

This section gives direction to fault diagnosis of load and radius errors as displayed on the display console. Load or radius errors may give rise to early or late tripping of overload alarms. Accuracy of load, radius, length, and angle is determined by the correct installation and maintenance of the system sensors.

Accuracy of load is governed by the radius accuracy, and the extension, angle, and pressure sensors.

Accuracy of radius (unloaded) is governed by the extension and angle sensors.

Before continuing, make sure that there are no system faults.

- **CHECK BOOM EXTENSION**

1. First check that the boom is fully retracted.
2. Check that the extension reel-off cable is correctly layered as a single layer across the extension reel surface. Any stacking of the cable will cause extension errors when the boom is fully retracted, causing the System to exceed the 0.5 ft tolerance allowed by the computer for boom mode selection. If the reel-off cable is stacking on the reel, see SECTION 6.2.
3. Check the zero of the extension sensor at the fully retracted boom position. Enter the Calibration Mode and use the "SPAN" command. Select sensor No. 2 to view the extension value in feet. The value of extension must be between -0.2 and +0.2, with the boom fully retracted. If the extension value is incorrect, follow the EXTENSION SENSOR SETUP procedure in SECTION 6.5.
4. Fully telescope the boom and check that the displayed boom length value matches the maximum length of the boom. If the length value is incorrect, follow the EXTENSION SPAN procedure in SECTION 6.5.3.

- **CHECK MAIN BOOM RADIUS**

NOTE

The required accuracy of taped radius measurements is within 0.1 feet.

When taking radius measurements; always use a good quality tape that does not stretch. The tape should be graduated in feet and tenths of feet. Always measure between the swing center of the crane and the hook line, using a single part of line, with the crane centered over front (rough terrain crane) or centered over rear (truck crane).

1. Fully retract the boom and make sure that the crane configuration is correctly set up.
2. Boom up to about 45° and measure the radius. The measured radius must match the displayed radius within +/- 0.2 ft. If it does **not** match, continue to the "CHECK BOOM ANGLE" procedure. If it does match, continue to "CHECK PRESSURE SENSORS."

Both procedures are on the next page.

- **CHECK BOOM ANGLE**

NOTE

The required accuracy of measured angles is within 0.2°.

When taking boom angle measurements; always use a good quality inclinometer. Many inclinometers are only accurate at 0° (level). Make sure that a reliable position on the top of the boom is used to measure the angle and that the inclinometer will provide an accurate reading at 0° (zero) and at 70°.

1. Fully retract the boom.
2. Using an inclinometer, set the boom to 0° (zero) and check that the displayed boom angle value is 0.0°. If the angle value is not 0.0°, follow SECTIONS 6.6, 6.9.1 and 6.9.2.
3. Boom up to a high angle (at least 70°) and measure the angle with the inclinometer. Check that the displayed angle matches the inclinometer reading within 0.2°. If the displayed angle is incorrect, follow the angle span calibration procedure in SECTION 6.9.3.

- **CHECK PRESSURE SENSORS**

The Pressure sensing system is factory calibrated, therefore pressure sensors may not be individually replaced. Any serious problems will necessitate changing the whole computer unit.

1. Boom fully down until the boom hoist cylinder is fully retracted and on its stop.
2. Loosen both hydraulic connections to the pressure sensors to guarantee *zero pressure is present* on the sensors.
3. Enter the CALIBRATION MODE and use the “PRESSURE MONITOR” command to view both sensor pressures and nett pressure.
4. Check the PRESSURE values of both sensors. The PRESSURE values should be between -75 and + 75 PSI. If not, replace the computer unit.
5. Check the NETT pressure. This should be between -35 and +35 psi. If not, replace the computer unit.

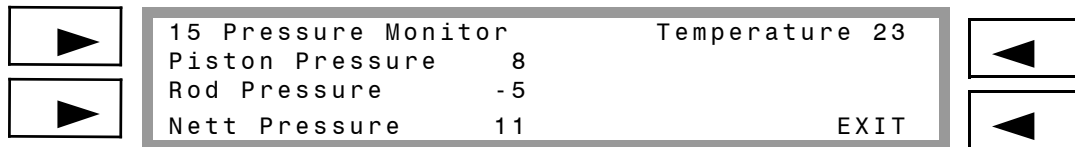

FIGURE 2.3 PRESSURE MONITOR

THIS PAGE INTENTIONALLY LEFT BLANK

SECTION 3 - COMPUTER UNIT

The COMPUTER UNIT SECTION defines troubleshooting techniques and limited replacement procedures.

3.1 COMPUTER UNIT OVERVIEW20

3.2 COMPUTER UNIT LAYOUT21

3.3 INTERNAL STATUS INDICATORS22

3.4 THE COMM INDICATOR23

3.5 COMPUTER UNIT REPLACEABLE PARTS.....24-26

 3.5.1 FUNCTION KICKOUT FUSE (FS2)..... 24

 3.5.2 SYSTEM CHIP (IC16).....25

 3.5.3 COMMUNICATIONS CHIPS (IC1, 2).....26

3.6 PRESSURE SENSORS27

3.7 REPLACING THE COMPUTER UNIT28

3.1 COMPUTER UNIT OVERVIEW

The COMPUTER UNIT, shown in Figures 3.1 and 3.2, is the center of the System. The computer unit provides all the necessary functions to read the sensors, control computations, disconnect functions, and communicate with the display console/internal bar graph.

The computer unit directly connects to the crane wiring harness via a 60-way bulkhead connector. There are no wiring connections or screw terminals within the unit.

Contained within the unit, are the two hydraulic pressure transducers required to sense pressure within the boom hoist cylinder. These sensors and the computer are factory pre-calibrated and, as such, may not be separately replaced in the field.

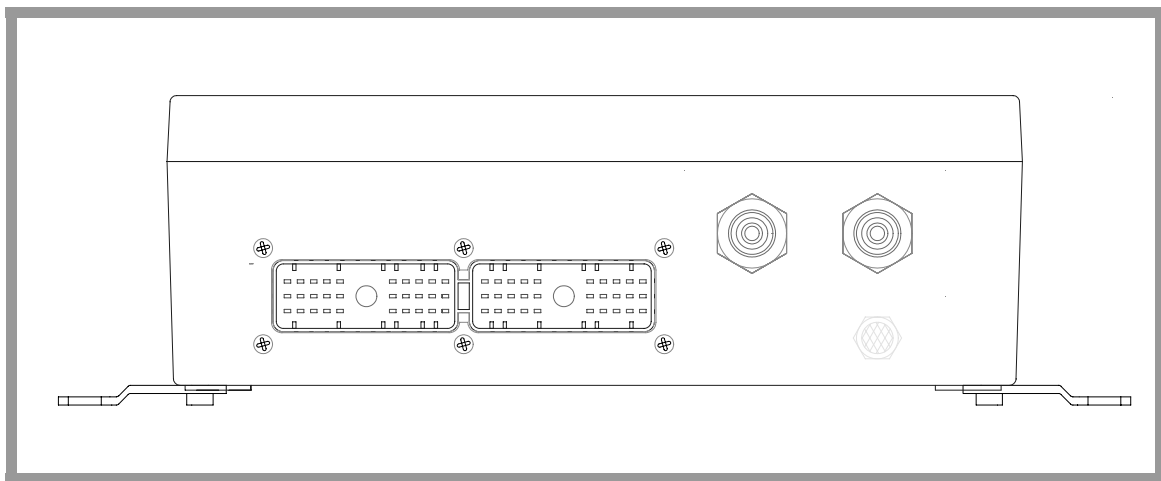

FIGURE 3.1 THE COMPUTER UNIT

3.2 COMPUTER UNIT LAYOUT

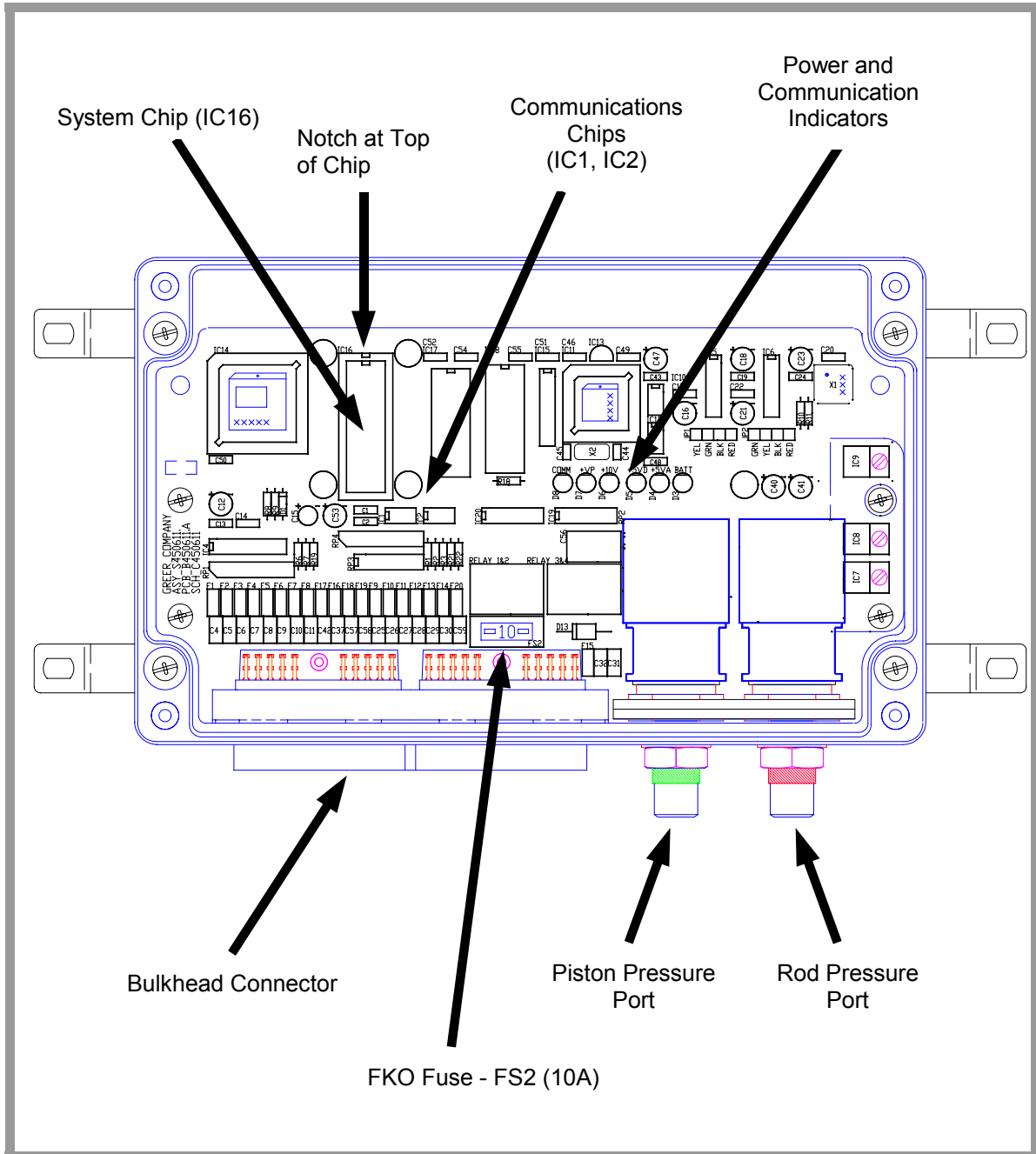

FIGURE 3.2 COMPUTER UNIT LAYOUT (LID REMOVED)

3.3 INTERNAL STATUS INDICATORS

The computer unit contains a row of indicators to aid in checking power supply and communications operation within the system. Remove the lid of the computer and check these indicators. Refer to the computer unit layout in Figure 3.2.

All the indicators are bright green light emitting diodes. There are five power indicators and one communication indicator (COMM). With the exception of the COMM indicator, all indicators should be illuminated at the same brightness level with the system power on.

A missing or dimly lit indication points to a power supply problem. Check the indicator chart below for repair actions.

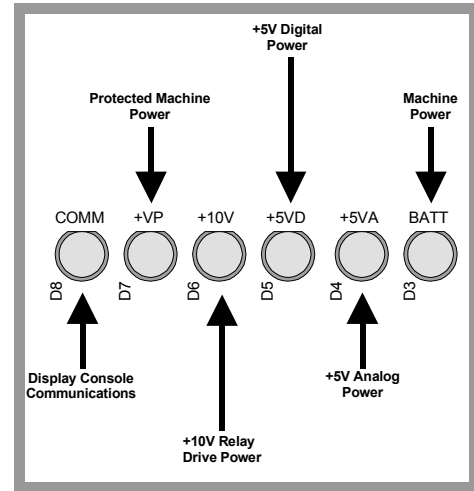

FIGURE 3.3 INTERNAL STATUS INDICATORS

Indicator states ● = Light OFF ○ = Light ON	Actions
COMM ● +VP ● +10V ● +5VD ● +5VA ● BATT ●	Check Crane power and circuit breaker.
COMM ● +VP ● +10V ● +5VD ● +5VA ● BATT ○	+VP power to display console shorted to crane ground. Check display console/bargraph cabling.
COMM ○ +VP ○ +10V ● +5VD ○ +5VA ○ BATT ○	+10V relay power internal short or regulator failure. Replace Computer.
COMM ● +VP ○ +10V ○ +5VD ● +5VA ● BATT ○	+5VD digital power internal short or regulator failure. Replace Computer
COMM ○ +VP ○ +10V ○ +5VD ○ +5VA ● BATT ○	+5VA analog power/drive to sensors. Check extension reel connection inside reel & wiring to extension reel.

FIGURE 3.4 INDICATOR STATES & ACTIONS

3.4 THE COMM INDICATOR

The COMM indicator provides an indication of the success or otherwise of communication with the display console, and of the running state of the computer program.

Carefully observe the COMM indicator and the display console at power on and through self-test; then, use the following chart to help decide the course of action.

See Figures 3.2 and 3.4 to locate the position of the COMM indicator.

COMM INDICATOR indications at power ON	ACTION
<p>From the moment the power is applied, the COMM indicator does not illuminate. During and after the self -test period of eight seconds, the COMM indicator remains off.</p>	<p>The computer is not running. Check status indicators. See SECTION 3.3. Try to reset the system by powering off and on again. Listen to the computer for the relays to click. If they do not click, replace the system chip. If not successful, replace the computer. If the relays do click, replace communication chips IC1, 2. See SECTION 3.5.3.</p>
<p>From the moment system power is applied, the COMM indicator flashes at a fast rate and never stops. The display console never goes to normal display and displays “88.8” or 888,000 in the number display windows.</p>	<p>Communication with the display has not been made. Check connector at rear of the display console.</p>
<p>At the moment power is applied, the COMM indicator flashes briefly, then switches off. After a few seconds, the COMM indicator starts to flash at a fast rate and never stops.</p>	<p>This is the normal operation of the communication between the computer and display console. If there are any problems with indications on the display console, go to SECTION 2.2.</p>

3.5 COMPUTER UNIT REPLACEABLE PARTS

The COMPUTER UNIT contains three parts that may be replaced in the field:

- A STANDARD 10 AMP AUTOMOTIVE FUSE, protecting the power feed to the function kickout circuit, is located on the circuit board within the unit.
- The system program/capacity chip, known as the SYSTEM CHIP (IC16).
- COMMUNICATIONS CHIPS (IC1, IC2) that communicate with the display console and are pluggable.

3.5.1 FUNCTION KICKOUT FUSE (FS2)

The computer unit contains a REPLACEABLE FUSE, illustrated in Figure 3.2, that protects the function kickout circuit and relay contacts, in the event that a short circuit across the crane kickout solenoids occurs.

The fuse, identified as FS2 on the computer board, may be replaced in the event that system error codes indicate that the function kickout power feed is missing, and it has been established that the crane circuit breaker is closed and power from the crane is present.

Before replacing the fuse, make sure that any electrical shorts that may have caused the failure of the original fuse have been removed.



When removing and installing the fuse,
ensure that the crane power is turned off.

3.5.2 SYSTEM CHIP (IC16)

The computer unit contains a replaceable SYSTEM CHIP, illustrated in Figure 3.2.

The system chip, identified as IC16 on the computer board, contains program data, capacity charts and calibration data for the crane and is a 28-pin dual-in-line (DIL) device. This chip **MUST MATCH** the load chart in the crane. Installation of the system chip does NOT necessitate recalibration of the System, but under certain circumstances may require a "RESET CRANE DATA" operation to be performed.

SYSTEM CHIP REMOVAL

1. Turn the power off.
2. Refer to Figure 3.2. Remove the chip from the computer board with a chip removal tool.

SYSTEM CHIP INSTALLATION

1. Use an installation tool to insert the new chip into the socket.
2. Ensure that the notch in the chip points to the upper side of the computer unit (opposite side to bulkhead connector and pressure ports).
3. Ensure that all pins are properly inserted into the chip socket. These pins are very easily bent.



When removing and installing chips, ensure that the power is off. Do not touch the chip pins unless you are properly grounded. Static electricity can damage chips.

Always use a proper IC removal tool. Use of screwdrivers, fingers, or other implements may damage the chip or seriously damage the circuit board. Recommended chip removal and installation tools may be obtained from Newark Electronics Stock No. 10F7494 and 10F7497.

Failure to have all pins inserted properly into the chip socket may cause damage to the System and the chip.

3.5.3 COMMUNICATIONS CHIPS (IC1, 2)

The computer unit contains two replaceable COMMUNICATIONS CHIPS, illustrated in Figure 3.2.

The communications chips, identified as IC1 and IC2, on the computer board provide communication of data between the computer unit and display console (as well as bar graph unit, if fitted). These chips are pluggable and replaceable. Replacement of the communications chip does NOT necessitate recalibration of the System.

It is unlikely that the communications chips will become damaged, but in the event that the COMM indicator remains off at all times, changing these devices may provide a solution. See INTERNAL STATUS INDICATORS and the COMM INDICATOR in this section).

COMMUNICATIONS CHIPS REMOVAL

1. Turn the power off.
2. Refer to Figure 3.2. Remove the chip from the computer board with a chip removal tool.

COMMUNICATIONS CHIPS INSTALLATION

1. Use an installation tool to insert the new chip into the socket.
2. Ensure that the dot on the top of the chip is at the same corner as the IC1, IC2 legend on the circuit board.
3. Ensure that all pins are properly inserted into the chip socket. These pins are very easily bent.



When removing and installing chips, ensure that the power is off. Do not touch the chip pins unless you are properly grounded. Static electricity can damage the chips.

Always use a proper IC removal tool. Use of screwdrivers, fingers, or other implements may damage the chip or seriously damage the circuit board.

Failure to have all pins inserted properly into the chip socket may cause damage to the System and the chip.

3.6 PRESSURE SENSORS

There are two PRESSURE SENSORS installed as part of a *MicroGuard*[®] *RCI-510* System. Both pressure sensors are mounted within the computer unit and electrically connected to the computer board within. One is connected to the PISTON side of the boom hoist cylinder via a flexible hose; the other to the ROD side of the boom hoist cylinder via a flexible hose. Both hoses are protected by velocity fuses within the boom hoist cylinder valve block on the end of the cylinder(s).

The pressure sensor on the piston side is subject to the hydraulic pressure necessary to support the weight of the boom, any attachments, and the load. The other sensor monitors the pressure necessary to control down motion of the boom. The computer unit uses this information (along with that from other sensors such as extension, length, and angle) to compute the weight of the suspended load. **The maximum continuous working pressure for these devices is 250 bar (3625 PSI).**

• **CHECKING PRESSURE SENSORS**

The pressure sensing system is factory calibrated, therefore pressure sensors may not be individually

WARNING

Both pressure sensors are factory pre-calibrated and supplied as part of the computer unit. Removal or replacement of these devices from the computer invalidates the warranty and will adversely affect the pressure calibration.

replaced. Any serious problems will necessitate changing the whole computer unit.

1. Boom fully down until the boom hoist cylinder is fully retracted and on its stop.
2. Loosen both hydraulic connections to the pressure sensors to guarantee zero pressure is present on the sensors.
3. Enter the CALIBRATION MODE and use the "PRESSURE MONITOR" command to view both sensor pressures and nett pressure.
4. Check the PRESSURE values of both sensors. They should be between -75 and + 75 PSI. If not, replace the computer unit.
5. Check the NETT pressure. This should be between -35 and +35 PSI. If not, replace the computer unit.

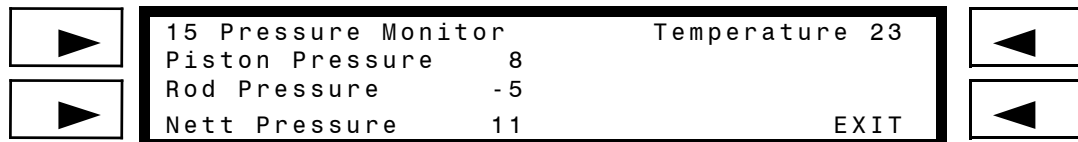

FIGURE 3.5 PRESSURE MONITOR

3.7 REPLACING THE COMPUTER UNIT

When changing the COMPUTER UNIT, it is strongly recommended that the SYSTEM CHIP be replaced at the same time. This ensures that the latest version of the chip is installed and guarantees that problems that may be caused by the existing chip are eradicated.

COMPUTER REMOVAL

1. Boom down all of the way so that the boom hoist cylinder is fully retracted or the boom is firmly in the boom rest.
2. Disconnect hydraulic connections at the computer unit.
3. Note which hose is connected to the piston and rod pressure ports.
4. Disconnect both electrical connectors at the computer unit.
5. Remove the hardware securing the computer to the cab wall.

COMPUTER INSTALLATION

1. Ensure that the correct system chip is installed in the computer.
2. Secure the computer unit to the cab wall with the mounting hardware.
3. Ensure that the electrical connections face downward.
4. Remove the two protective covers from the electrical bulkhead connector.
5. Connect the electrical connectors.
6. Remove the protective caps from the hydraulic ports.
7. Connect the base-side pressure hose to the piston pressure port.
8. Connect the rod-side pressure hose to the rod pressure port.

POWER UP AND CALIBRATION

1. Switch the crane power on and check that all LED check lights within the computer unit are illuminated. Ensure that the COMMS LED is flashing and that the display console is operating.

CHECKS:

- With an inclinometer, check the accuracy of the boom angle and the radius measurements and tape at four or five points.
- Ensure that the hydraulic connections are secure and not leaking at the computer unit.
- Secure the computer lid and rain cover.

THIS PAGE INTENTIONALLY LEFT BLANK

THIS PAGE INTENTIONALLY LEFT BLANK

SECTION 4 - DISPLAY CONSOLE

4.1 DISPLAY CONSOLE OVERVIEW.....32

4.2 DISPLAY CONSOLE MODELS32

4.3 CHECKING THE DISPLAY CONSOLE 32-33

 4.3.1 READING THE (LIQUID CRYSTAL) DISPLAYS32

 4.3.2 BUTTONS THAT DON'T RESPOND33

 4.3.3 CONNECTORS 33

 4.3.4 HORN33

 4.3.5 MOISTURE33

4.4 REPLACING THE DISPLAY CONSOLE 34

4.1 DISPLAY CONSOLE OVERVIEW

The OPERATOR'S DISPLAY CONSOLE (Figure 4.1) allows the user to see the crane values (angle, radius, load, etc.) and crane configuration selection. The display also provides calibration functions used for testing and fault diagnosis.

4.2 DISPLAY CONSOLE MODELS

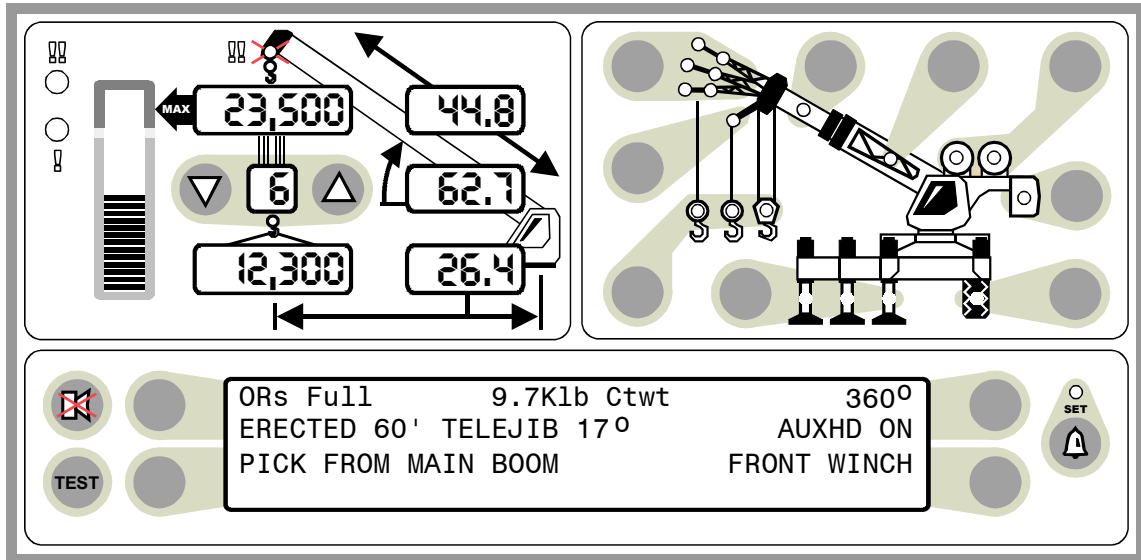

FIGURE 4.1 OPERATOR'S DISPLAY CONSOLE

4.3 CHECKING THE DISPLAY CONSOLE

The OPERATOR'S DISPLAY CONSOLE is normally very reliable. However, when operated for extended periods, under extreme conditions, the console can become damaged. The damage is not always apparent. To help identify subtle faults that are sometimes difficult to find, or that may be attributed, mistakenly, to other kinds of problems, please review the following comments.

4.3.1 READING THE (LIQUID CRYSTAL) DISPLAYS

Always adjust the display contrast first. On bracket-mounted models only, reposition the display console slightly. The most commonly encountered problem is caused by reflections.

NOTE: It may not be possible to correct this problem completely, especially on flush-mounted display consoles exposed to bright sunlight. If the problem concerns the contents of one or more of the display screens, refer to the PROBLEM FINDER FLOW CHARTS in SECTION 2 of this manual.

4.3.2 BUTTONS THAT DON'T RESPOND

All button options are not available for use at all times. Ensure that the non-responsive button is programmed to respond at that point in the operation of the System. Press the button in the center. Pressing the printed symbol 'at one end' may not activate the switch underneath. Buttons that are damaged or have a surface that is worn may cause the switch underneath to operate improperly.

In this case, refer to OPERATOR'S DISPLAY CONSOLE

– REMOVAL AND INSTALLATION.

4.3.3 CONNECTORS

A SINGLE CIRCULAR CONNECTOR, common to all display models, is positioned on the rear of the display console. On the bracket-mounted style, it is clearly visible on the rear of the housing. On the flush-mounted versions, it is 'hidden' behind the panel, within the dash assembly. This connector carries power and signals from the computer unit to the display console. Examine this connector carefully. It is possible for the pins and sockets within the connector halves to bend, break, or 'be pushed back' inside the housing.

On FLUSH-MOUNTED DISPLAY CONSOLES (VERTICAL MODEL), ONE ADDITIONAL CONNECTION, besides the circular connector, is required: The HORN DRIVE WIRE is a single black lead that should be attached to the black terminal on the rear of the display console housing.

4.3.4 HORN

On vertical FLUSH-MOUNTED CONSOLES, the HORN is outside the housing. If there is a problem with the horn, ensure that the HORN DRIVE WIRE is connected correctly to the black terminal on the rear of the display console housing. Release the display console from its connections and pull it gently forward. If the wire is intact and connected correctly and the horn is still not operating correctly, the horn may need to be replaced. If possible, test the horn operation by temporarily installing another horn known to operate correctly.

4.3.5 MOISTURE

The DISPLAY CONSOLE offers protection against dust and water, when correctly installed.

4.4 REPLACING THE DISPLAY CONSOLE

REMOVAL

1. Disconnect the electrical cable from the electrical connector on the rear of the OPERATOR'S DISPLAY CONSOLE.
2. Remove the defective operator's display console from the bracket in the cab by removing the knob on each side of the console. Retain the knobs for future use.

INSTALLATION

1. Install the new OPERATOR'S DISPLAY CONSOLE on the bracket in the cab by positioning it between the bracket legs and inserting and tightening the knob on each side of the console.
2. Connect the electrical cable to the electrical connector on the rear of the console.

SECTION 5 - REMOTE BAR GRAPH

5.1 REMOTE BAR GRAPH OVERVIEW 36

5.2 CHECKING THE REMOTE BAR GRAPH 36-37

 5.2.1 LAMPS 36

 5.2.2 BRIGHTNESS CONTROL..... 36

 5.2.3 CABLE AND CONNECTOR 37

 5.2.4 MOISTURE..... 37

5.3 REMOTE BAR GRAPH REPLACEMENT 37

5.1 REMOTE BAR GRAPH OVERVIEW

The REMOTE BAR GRAPH, shown below, displays the percentage of rated capacity of the crane. The remote bar graph is mounted at the top of the cab front window, in the operators line of sight. User-selectable levels of brightness are available on the device, which is designed for reading under all lighting conditions. Defective remote bar graphs cannot be serviced.

The remote bar graph is optional and is not used on all cranes.

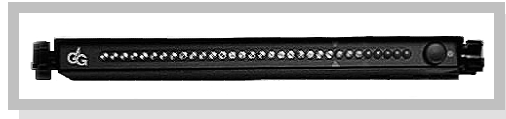

FIGURE 5.1 REMOTE BAR GRAPH

5.2 CHECKING THE REMOTE BAR GRAPH

The REMOTE BAR GRAPH is normally very reliable. However, when operated for extended periods, under extreme conditions, the device can become damaged. The damage is not always apparent. To help identify subtle faults that are sometimes difficult to find, or that may be attributed, mistakenly, to other kinds of problems, please review the following comments.

5.2.1 LAMPS

The 'LAMPS' are LIGHT EMITTING DIODES (LED's). They are more reliable than standard incandescent bulbs and consume far less power. LED operation can be checked at any time by the operator by pressing the test button on the operator's display console. Always replace the entire bar graph unit if it is found to be faulty.

With the System powered, there should always be at least one (GREEN) LED lighted – the one **furthest** from the BRIGHTNESS CONTROL push button, even when there is no load suspended. The REMOTE BAR GRAPH LED's should 'track' or 'echo' the bar graph on the operator's display console at all times.

5.2.2 BRIGHTNESS CONTROL

There are four levels of brightness. Holding the BRIGHTNESS CONTROL BUTTON continuously will cause the unit to automatically 'cycle' through the available levels. Release the button at any time to select the desired setting. Alternately pressing and releasing the button will cause the cycle to progress through the four levels in sequence. It is **not** possible to 'switch-off' the LED's using this control.

The currently selected brightness level is not stored within the **MicroGuard**[®] System when the power is switched off. Therefore, the brightness desired will have to be set again manually when the System is next used. The remote bar graph always starts with the LED's set to MAXIMUM brightness.

5.2.3 CABLE AND CONNECTOR

The REMOTE BAR GRAPH uses a single cable to communicate with the computer unit and to carry power. The cable is nonremovable and is a fixed length. Excess cable should be stored (not discarded) when the unit is installed. Extending this cable is not recommended.

There is a single connector on the far end of this cable. This connector carries power and various signals between the computer unit and the remote bar graph. Because of the nature of connectors, it is possible for the pins and sockets within the connector halves to be damaged. A pin may be bent, broken, or 'pushed back' inside the housing.

5.2.4 MOISTURE

The REMOTE BAR GRAPH offers adequate protection against dust and water when correctly installed. It is not possible, however, to fully protect the sensitive electronic assembly inside against pressure-washing or heavy rainfall. If this occurs, the remote bar graph should be replaced.

5.3 REMOTE BAR GRAPH REPLACEMENT**REMOVAL OF REMOTE BAR GRAPH**

1. Turn off the power.
2. Remove the display console in order to access cabling in connectors.
3. Disconnect the remote bar graph cable from the display console wire harness at the rear of the display console.
4. Remove the remote bar graph from its bracket by loosening and removing the knob at each end of the remote bar graph. Retain the knobs for reuse.

INSTALLATION OF REMOTE BAR GRAPH

1. Put the new remote bar graph in position. Reconnect and tighten the two knobs.
2. Route the cable to the display console and connect the cable.
3. Turn on the power and ensure that the remote bar graph operates correctly.

SECTION 6 - EXTENSION REEL

6.0 ENTERING THE CALIBRATION MODE39

6.1 EXTENSION REEL OVERVIEW40

6.2 CHECKING THE REEL-OFF CABLE LAYERING.....41

6.3 CHECKING THE EXTENSION SENSOR DRIVE VOLTAGE42

6.4 CHECKING THE BOOM EXTENSION SENSOR VOLTAGE42

6.5 EXTENSION SENSOR SETUP.....43

 6.5.1 PHYSICAL ZERO.....43

 6.5.2 ZERO CALIBRATION43

 6.5.3 SPAN CALIBRATION44

6.6 CHECKING THE ANGLE SENSOR PENDULUM.....45

6.7 CHECKING THE ANGLE SENSOR DRIVE VOLTAGE46

6.8 CHECKING THE ANGLE SENSOR VOLTAGE46

6.9 ANGLE SENSOR SETUP47

 6.9.1 PHYSICAL ZERO.....47

 6.9.2 ZERO CALIBRATION48

 6.9.3 SPAN CALIBRATION48

6.10 EXTENSION REEL REPLACEABLE PARTS 49-56

 6.10.1 EXTENSION REEL-OFF CABLE..... 49-51

 6.10.2 SLIP-RING ASSEMBLY..... 51-52

 6.10.3 SENSOR BASEPLATE ASSEMBLY..... 53-54

 6.10.4 SIGNAL CABLE ASSEMBLY..... 55-56

6.0 ENTERING THE CALIBRATION MODE

To perform the calibration sequences shown in this and in the following sections of this manual, it will be necessary to access the “Calibration Mode” followed by entry of the “Security Code.”

1. To access the “Calibration Mode,” locate the “Test” and “Set” keys on the Display Console, as shown below, and press both keys simultaneously for about two seconds.
2. Enter the “Calibration Security Code,” by pressing the keys identified below as 1234 in that sequence.

If the wrong Calibration Security Code number sequence is used or if the Calibration Security Code entry is not completed within 5 seconds, the entry will be aborted and **must be entered again**.

THIS CODE WILL BE USED WHENEVER CALIBRATION IS REQUIRED. IT IS HELPFUL TO MEMORIZE THESE KEY POSITIONS, AS SHOWN IN FIGURE 6.0 BELOW.

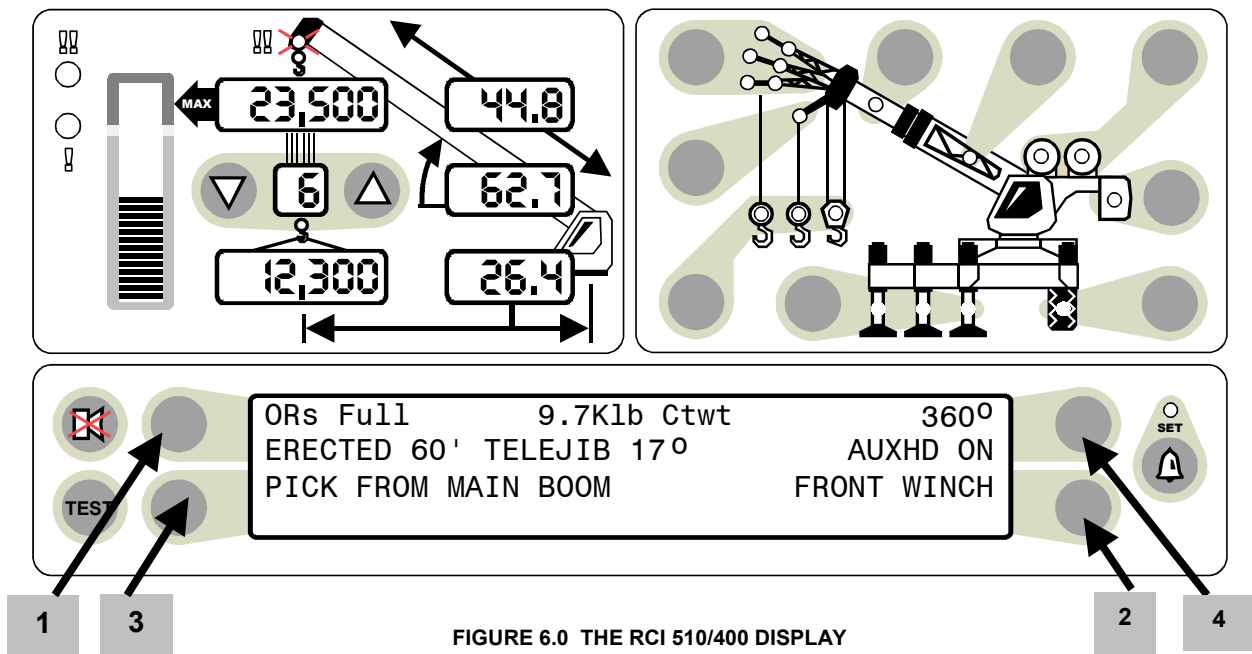

FIGURE 6.0 THE RCI 510/400 DISPLAY

6.1 EXTENSION REEL OVERVIEW

The primary operation of the EXTENSION REEL is to measure the extension of the telescoping sections of the main boom. The extension reel also includes an angle sensor to measure the main boom angle, and an electrical slip-ring which transfers the Two-Block signal from the reel-off cable to the system computer.

The extension reel is designed to provide a very accurate measurement of extension and angle. It is important that the setting up and maintenance of these devices be properly carried out as per the procedures contained within this manual. Incorrect maintenance will result in system calculation errors.

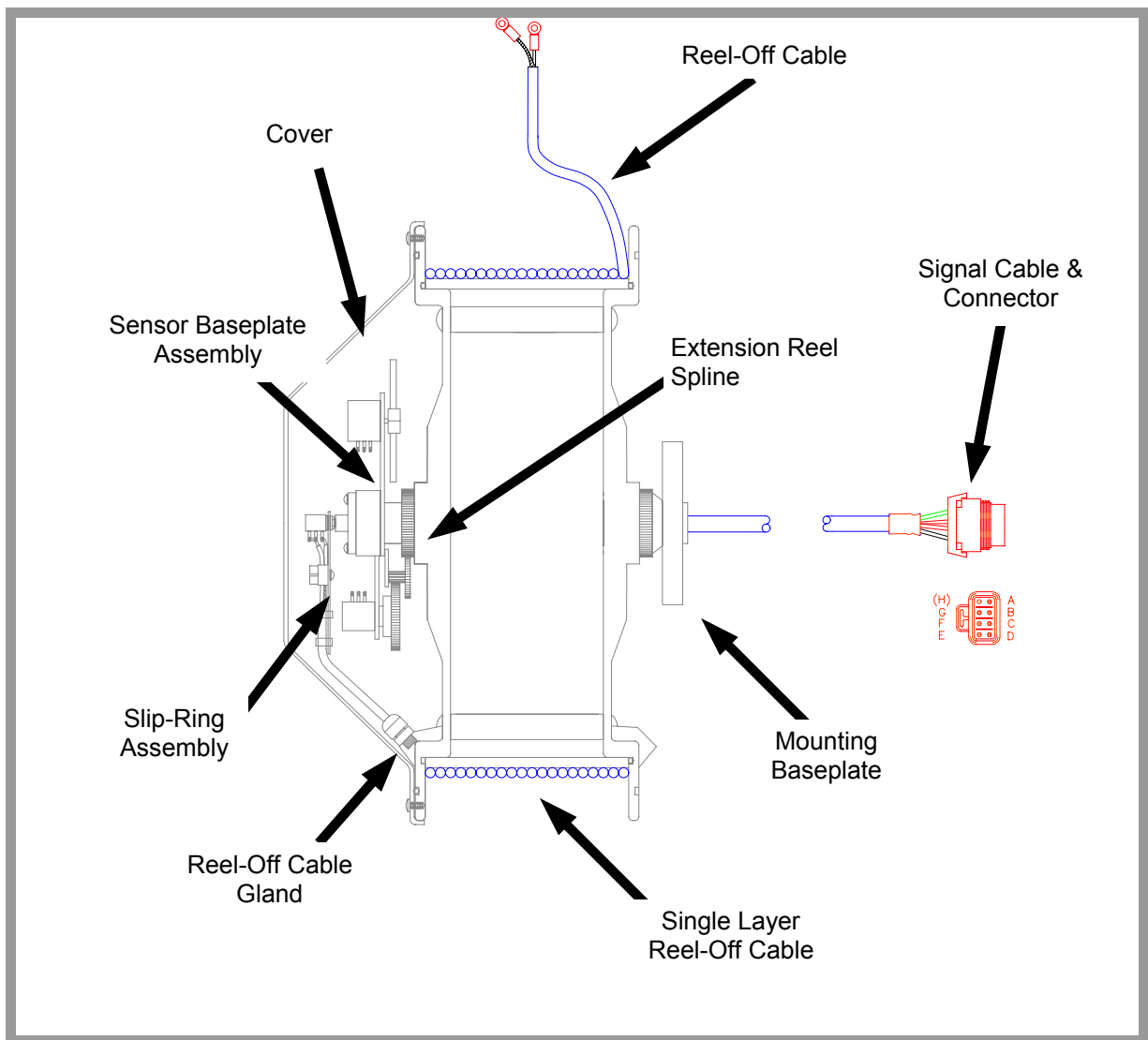

FIGURE 6.1 EXTENSION REEL CUT-AWAY DRAWING

6.2 CHECKING THE REEL-OFF CABLE LAYERING

The extension reel is designed to provide accurate measurement of boom extension when the REEL-OFF CABLE forms a single flat layer across the surface of the extension reel as the boom is telescoped in and out. Any stacking of the cable will cause extension errors as the boom retracts.

1. Telescope the boom fully out and then fully in.
2. Check that the reel-off cable forms a flat single layer across the surface of the extension reel, with each successive turn of cable laying next to the last.

If any stacking or build up of the cable occurs, make sure that the first cable guide at the top of the boom root section is correctly aligned with the outside edge of the extension reel, as shown in Figure 6.2 below.

Clean the reel-off cable; then lubricate it with a silicone oil.

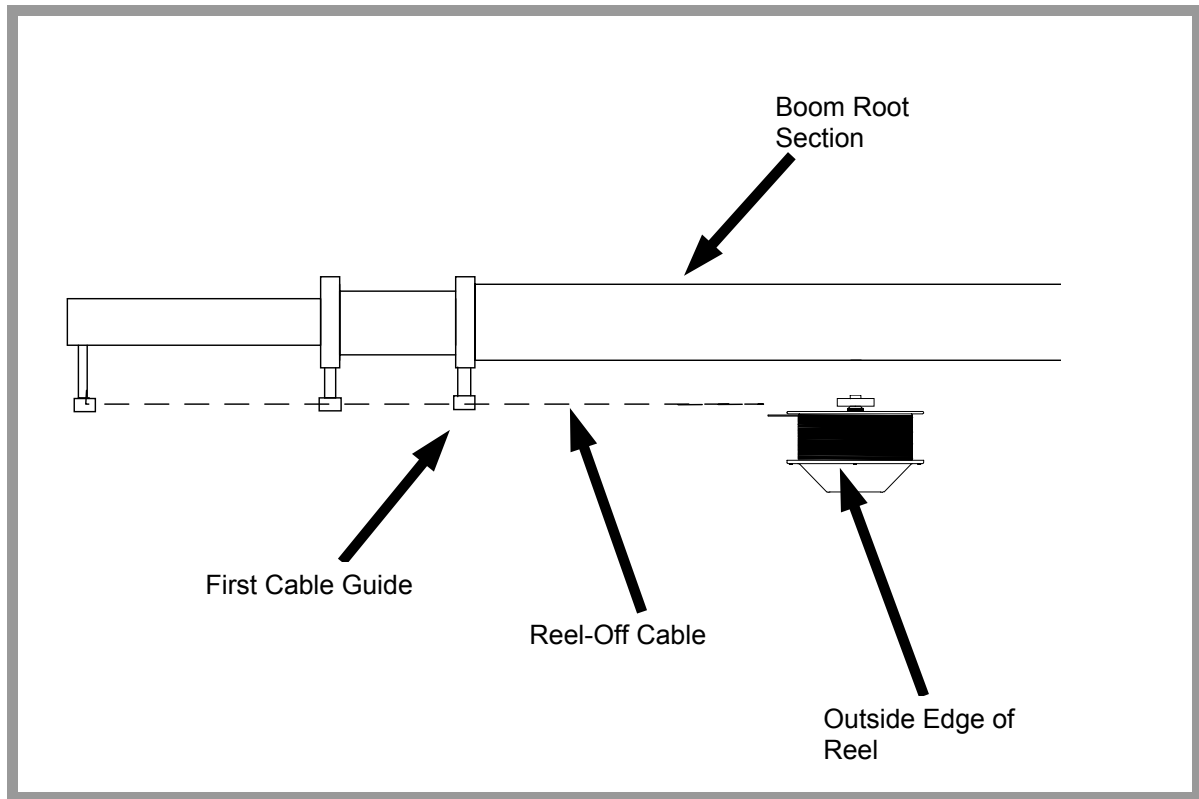

FIGURE 6.2 EXTENSION REEL VIEWED FROM ABOVE

6.3 CHECKING THE EXTENSION SENSOR DRIVE VOLTAGE

1. Remove the extension reel cover.
2. Using a digital voltmeter, measure the voltage between the RED (TB1-4) and BLUE (TB1-1) wires at the terminal block mounted on the sensor baseplate assembly.
3. Check that the voltage is between 4.7 and 5.3 volts.

Voltages outside the range specified above will indicate an interconnection problem between the extension reel and the computer or, a short circuit within the extension reel. Check extension reel wiring within the reel and at connector J305.

6.4 CHECKING THE BOOM EXTENSION SENSOR VOLTAGE

1. Fully retract the boom.
2. Remove the extension reel cover.
3. With a digital voltmeter, measure the voltage between the BLUE wire (TB1-1) and the WHITE wire (TB1-3).
4. With the boom fully retracted, the voltage should be between 0.1 and 0.3 volts. If the voltage is incorrect, follow the EXTENSION SENSOR SETUP PROCEDURE.
5. Still measuring the voltage at the same points, telescope the boom out and check that the

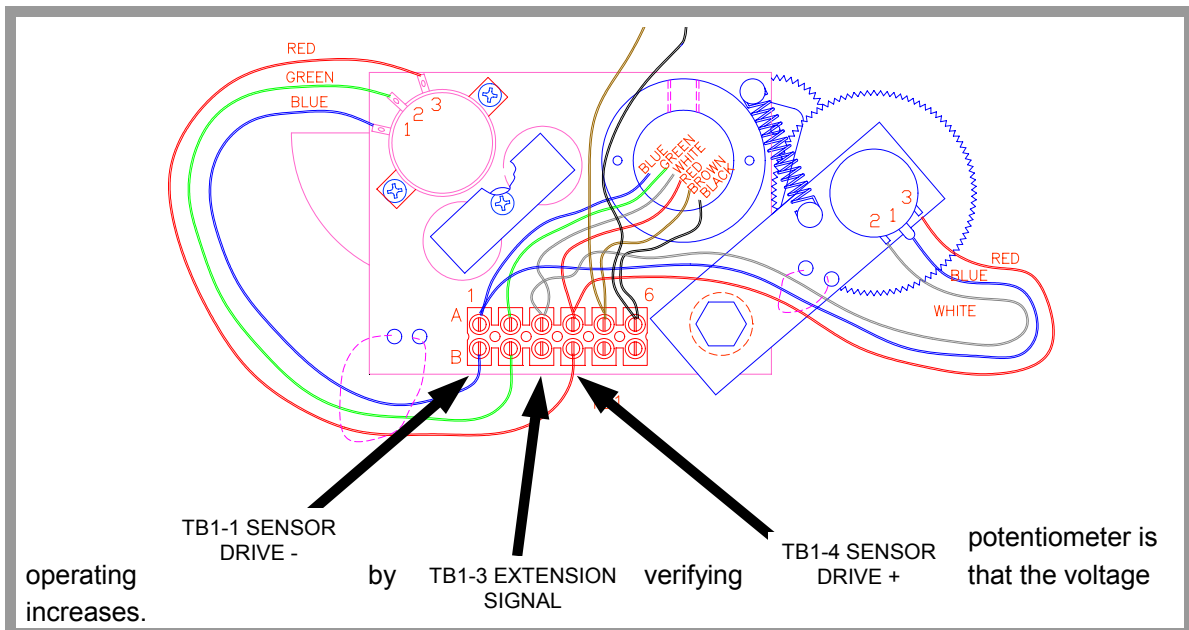

FIGURE 6.3 SENSOR BASEPLATE ASSEMBLY WIRING

6.5 EXTENSION SENSOR SETUP

The following procedures define how to reset and calibrate the EXTENSION SENSOR, if necessary. Before any of these procedures are used, check that the reel-off cable is layering correctly (SECTION 6.2).

6.5.1 PHYSICAL ZERO

It is necessary to ensure that the extension sensor potentiometer is correctly set to its minimum “zero” setting when the boom is fully retracted. This ensures that the sensor will correctly measure over the full telescoping range of the boom.

1. Fully retract the boom.
2. With the cover of the extension reel removed, disengage the main gear wheel connected to the extension sensor by pulling the sensor arm in the direction shown.
3. Rotate the gear clockwise until the sensors clutch detonate starts to click. At the next click, stop rotating the gear.
4. Measure the voltage between TB1-3 and TB1-1 (Figure. 6.3).
5. Rotate the gear counterclockwise about half a turn setting the voltage to 0.2 volts. Then, carefully release the sensor arm, ensuring that the voltage remains at 0.2 volts as the gears re-engage.

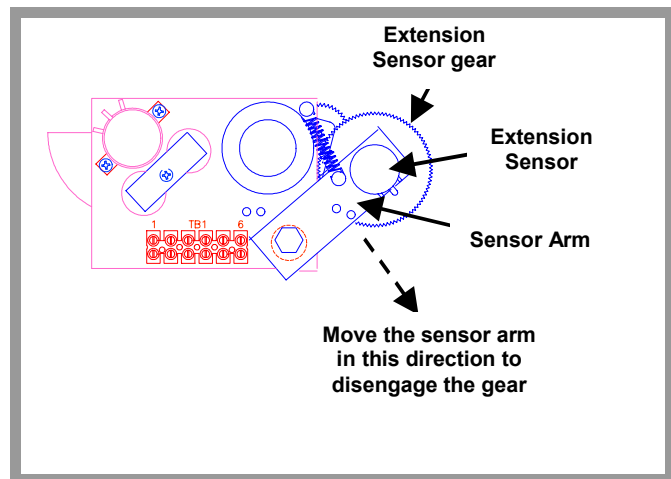

FIGURE 6.4 SENSOR ASSEMBLY

6.5.2 ZERO CALIBRATION

The computer must identify where the ZERO POINT of the extension sensor has been set (see above). It is therefore necessary to calibrate the zero setting of the potentiometer.

Before continuing, ensure that the mechanical zero has been properly set. See SECTION 6.5.1.

1. Fully retract the boom.
2. Enter the calibration mode at the display console. (Refer to Calibration Mode Entry, page 39.)
3. Select Command 02, SENSOR ZERO
4. Select sensor No. 2.
5. Zero the extension sensor.
6. Before exiting the command, ensure that the displayed value is between -4 and +4.

6.5.3 SPAN CALIBRATION

The computer must be able to treat measurements of distance provided by the extension sensor. It is therefore necessary to calibrate the SPAN of the extension potentiometer.

Before continuing, ensure that the calibration zero has been properly set, as described in SECTION 6.5.2, page 43.

1. Fully extend the boom.
2. Enter the CALIBRATION MODE at the display console.
(Refer to Calibration Mode Entry, page 39.)
3. Select Command 03, SENSOR SPAN.
4. Select sensor No. 2.
5. Calibrate the SPAN value, which is the fully extended boom length — (minus) the fully retracted boom length.
6. Before exiting the Command, check that the displayed value is within ± 0.2 of the extension value calculated in No. 5 above.

6.6 CHECKING THE ANGLE SENSOR PENDULUM

The ANGLE SENSOR uses a copper PENDULUM, mounted behind the sensor assembly. In order to stop the pendulum from swinging uncontrollably during movements of the boom, two magnets provide damping.

If problems with the angle sensor are suspected, check that the pendulum and potentiometer are operating without restriction, before continuing to check electrical operation and performing any calibration.

1. Remove the extension reel cover.
2. Locate the PENDULUM. Refer to Figure 6.5 below.
3. Push the pendulum downwards in the direction shown and ensure that it doesn't feel as if it is sticking. Some resistance of movement may be encountered as the pendulum is moved; however, this is due to the magnets that provide the damping.
4. Release the pendulum and make sure that it returns with free, but controlled movement, directly back to its original position.
5. Push the pendulum downwards a few more times, checking that it returns, each time, to its starting position.

NOTE: If any "sticking" of the pendulum is encountered while performing the above checks, ensure that there are no wires touching the pendulum, or that other obvious problems are present. If not, it will be necessary to replace the sensor assembly.

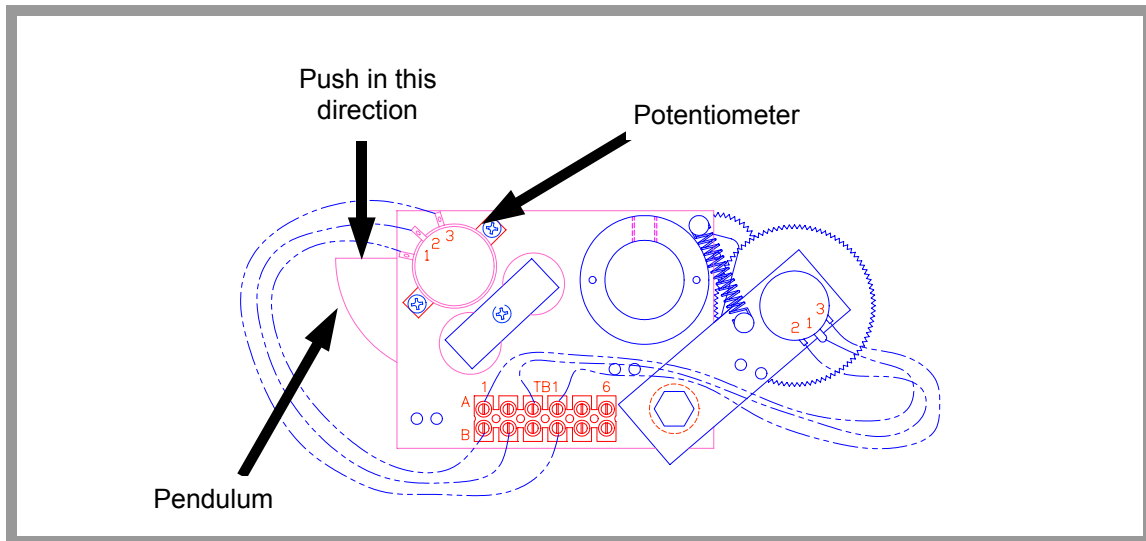

FIGURE 6.5 SENSOR ASSEMBLY

6.7 CHECKING THE ANGLE SENSOR DRIVE VOLTAGE

1. Remove the extension reel cover.
2. Using a digital voltmeter, measure the voltage between the RED (TB1-4) and BLUE (TB1-1) wires at the terminal block mounted on the sensor baseplate assembly.
3. Check that the voltage is between 4.7 and 5.3 volts.

Voltages outside the range specified above will indicate an interconnection problem between the extension reel and the computer or, a short circuit within the extension reel. Check extension reel wiring within the reel and at the boom foot base connector.

6.8 CHECKING THE ANGLE SENSOR VOLTAGE

4. Using an inclinometer for verification, place the main boom at a 0° (zero) angle; then remove the extension reel cover.
5. With a digital voltmeter, measure the voltage between the BLUE wire (TB1-1) and the GREEN wire (TB1-2). With the boom horizontal, the voltage should be between 0.3 and 0.5 volts. If the voltage is incorrect, follow the ANGLE SENSOR SETUP PROCEDURE.
6. Still measuring the voltage at the same points, move the exposed side of the angle sensor pendulum downwards, and check that the potentiometer is operating by verifying that the voltage increases.
7. Check that the pendulum moves freely, and when released, falls smoothly back to the original 0° (zero) voltage reading, as measured in Step 5.

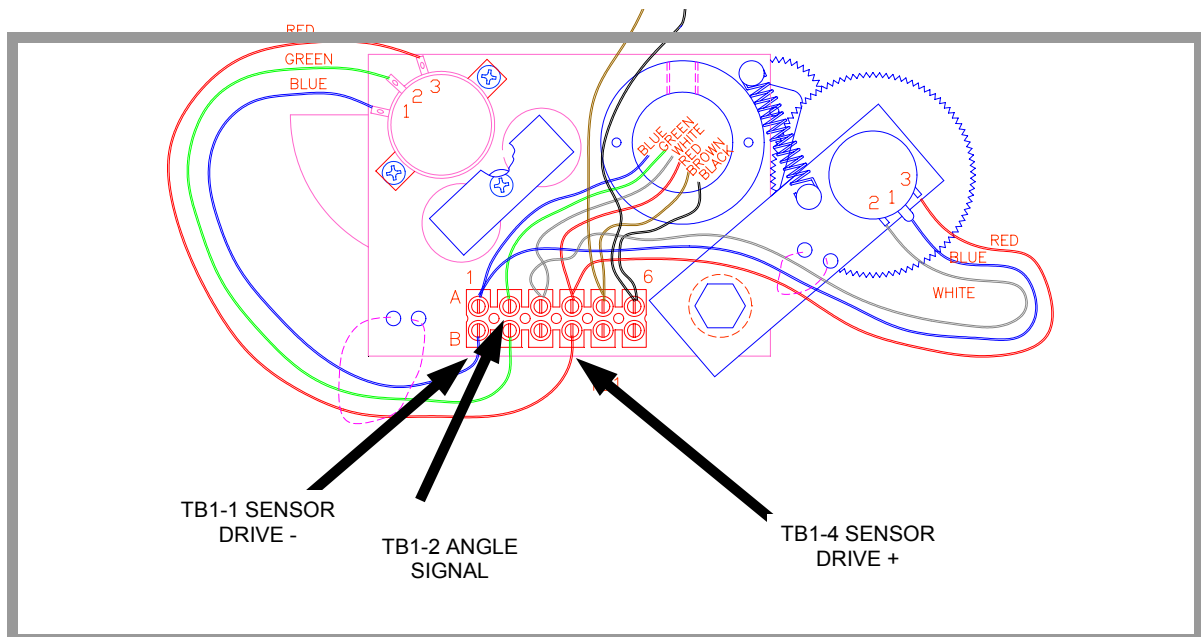

FIGURE 6.6 SENSOR BASEPLATE ASSEMBLY WIRING

6.9 ANGLE SENSOR SETUP

The following procedures define how to reset and calibrate the ANGLE SENSOR, as required.

6.9.1 PHYSICAL ZERO

It may be necessary to ensure that the angle sensor potentiometer is correctly set to its physical “zero” setting with the boom at 0° (ZERO). This ensures that the sensor will correctly measure the full angle range of the boom.

1. Using an inclinometer, set the boom to 0° (ZERO).
2. Loosen the two securing screws on either side of the sensor potentiometer just enough to allow the sensor potentiometer to be turned by hand. Do not remove the screws and do not put pressure on the terminals exiting the sensor.
3. Measuring the voltage between TB1-2 and TB1-1 (see Figure 6.7), carefully rotate the potentiometer until the voltage measures 0.4 volts. Rotating the sensor counterclockwise will increase the voltage. Rotating clockwise will reduce the voltage. Only fine adjustments are required. Do not touch the pendulum hanging behind the sensor assembly, as this will affect the reading.
4. Tighten the securing screws and check that the voltage remains at 0.4 volts.

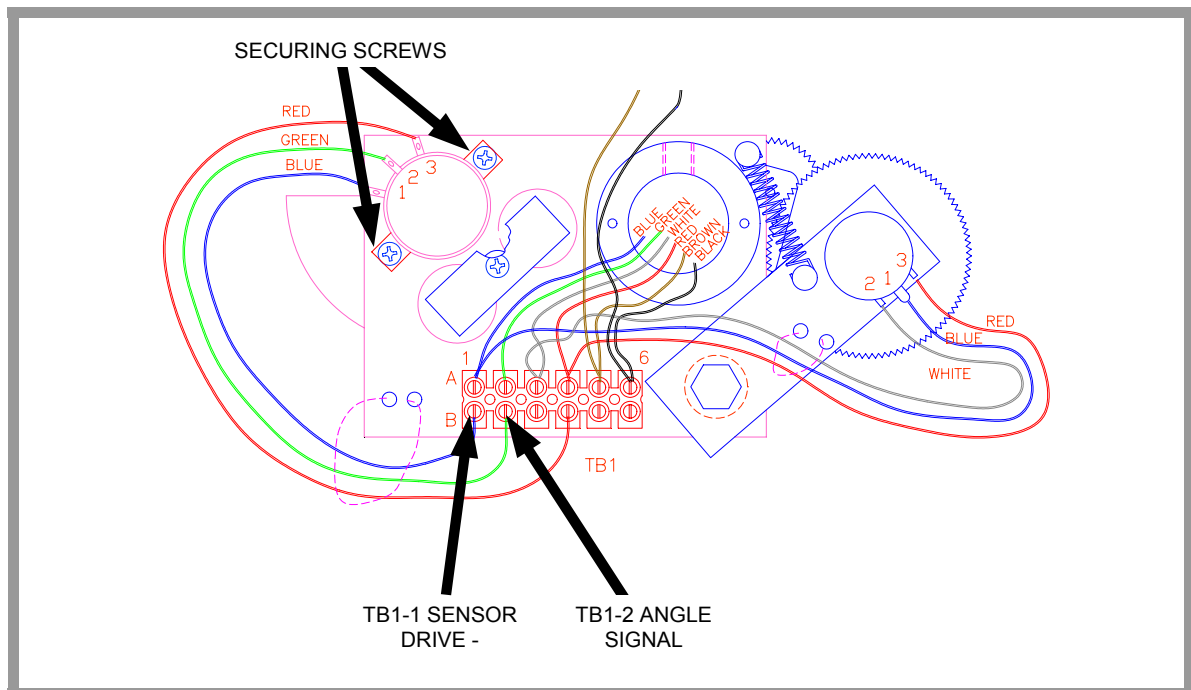

FIGURE 6.7 SENSOR BASEPLATE ASSEMBLY WIRING

6.9.2 ZERO CALIBRATION

The computer must be able to identify where the ZERO point of the angle sensor has been set. It is, therefore, necessary to calibrate the zero setting of the potentiometer.

Before continuing, make sure that the mechanical (physical) zero has been properly set, as described in Section 6.9.1.

1. Using an inclinometer, set the boom to 0° (zero).
2. Enter the CALIBRATION MODE at the display console. (Refer to Calibration Mode Entry, page 39.)
3. Select Command 02, SENSOR ZERO
4. Select sensor No. 3.
5. Zero the angle sensor.
6. Before exiting the command, check that the displayed value is between -4 and +4.

6.9.3 SPAN CALIBRATION

The computer must be able to treat measurements of the angle provided by the angle sensor. It is therefore necessary to calibrate the SPAN of the angle potentiometer.

Before continuing, ensure that the calibration zero has been properly set, as described in SECTION 6.9.2.

1. Boom up to a high angle (at least 70°) and measure the angle with an inclinometer.
2. Enter the CALIBRATION MODE at the display console. (Refer to Calibration Mode Entry, page 39.)
3. Select Command 03, SENSOR SPAN
4. Select sensor No. 3.
5. Calibrate the angle span using the angle as measured in step 1.
6. Before exiting the command, check that the displayed value is between -0.1° and +0.1° of the value entered.

NOTE

The required accuracy of measured angles is within 0.2°.

When taking boom angle measurements; always use a good quality inclinometer. Many inclinometers are only accurate at 0° (level). Ensure that a reliable position on the top of the boom is used to measure the angle and that the inclinometer will provide an accurate reading at 0° and at 70°.

6.10 EXTENSION REEL REPLACEABLE PARTS

The EXTENSION REEL is field-serviceable in every respect except for the spring chamber/extension reel surface and shaft assembly. Failure of the recoil spring, damage to the shaft or reel surface and side plates requires complete replacement of the extension reel.

The following parts of the extension reel, are field-replaceable:

- EXTENSION/REEL-OFF CABLE ASSY
- SLIP-RING ASSEMBLY
- SENSOR BASEPLATE ASSEMBLY
- CABLE TAIL ASSEMBLY (SIGNAL CABLE)
- COVER

6.10.1 EXTENSION REEL-OFF CABLE

The EXTENSION REEL-OFF CABLE, running from the extension reel to the main boom head, carries the Anti Two-Block signal from the switches at the main boom head, aux head and erected jib/fly. The cable is made from stainless steel wire and a durable outer sheath. Damage to the cable will often result in bad Two-Block signals or bad measurement of boom extension. If the cable has been broken or damaged in any way, it can be field-replaced.

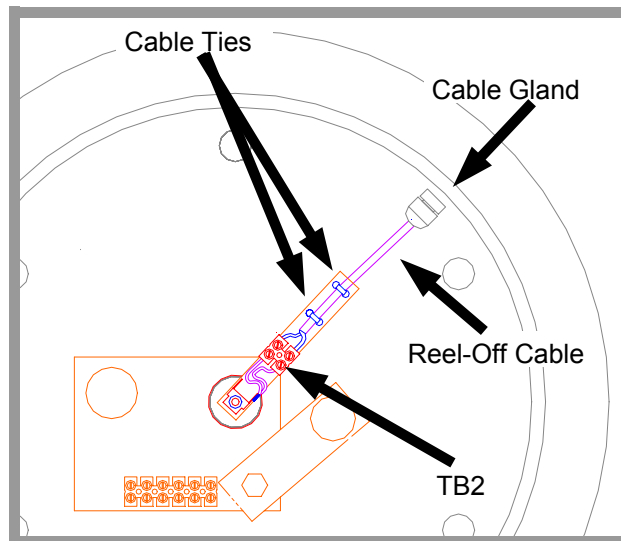

FIGURE 6.8 REEL-OFF CABLE CONNECTION ON THE EXTENSION REEL

REMOVING THE EXTENSION REEL-OFF CABLE

1. Fully retract and lower the boom. Then, disconnect the REEL-OFF CABLE from the Anti Two-Block switch or connector.
2. Gripping the cable firmly, release it from the tie-off post.
3. Continue to grip the cable firmly while allowing it to fully wind back onto the extension reel.
4. Remove the extension reel cover.
5. Cut the 2 tie-wraps that secure the extension reel-off cable to the slip-ring support arm.
6. Unscrew the extension reel-off cable from the terminal block on the slip-ring support arm.
7. Loosen the gray cable gland mounted on the cheekplate.
8. Pull the existing extension reel-off cable out through the cable gland.

INSTALLING THE EXTENSION REEL-OFF CABLE

1. Loosen the strain relief on the cheekplate and feed the EXTENSION REEL-OFF CABLE through the wall of the cheekplate. Leave enough slack to work easily with the cable.
2. If not already stripped, remove 1" of the outer jacket of the cable with an X-ACTO knife.
3. Unravel the stainless steel braid and twist it into a single wire.
4. Remove 1/4" insulation from the center wire. The insulation bonded to the center wire is difficult to remove. Remove small increments about 0.1" at a time with wire strippers.
5. Connect the extension reel-off cable to TB2 on the arm of the slip-ring. The braided wire connects to the black wire and the center core connects to the brown wire. Using two cable ties, tie the cable to the arm of the slip-ring.
6. Secure the extension reel-off cable to the arm of the slip-ring with 2 tie-wraps.
7. Adjust the cable to bend slightly from the strain relief to the slip-ring. Rotate the extension reel. Ensure that the path of the new cable is unimpeded; then, tighten the strain relief.
8. Wind the extension reel-off cable onto the extension reel in a single layer.
9. Set pre-tension (5 turns counterclockwise). Thread the extension reel off-cable through the cable guides. Attach the cable to the boom tie-off-post and connect it to the Anti Two-Block switch.
10. Follow the EXTENSION SENSOR SETUP PROCEDURE to set the potentiometer zero. Recalibration of the extension span should not be necessary.
11. Fully telescope the boom in and out at least twice, ensuring that the reel-off cable remains in a single flat layer on the drum surface and the length display on the display console is accurate with a fully extended or fully retracted boom. Any stacking of the cable on the extension reel surface will cause measurement errors. If this is the case, it may be necessary to check that the first cable guide aligns correctly with the outside edge of the extension reel surface.

12. Reinstall the cover of the extension reel, ensuring that the "O" ring on the inside of the Extension Reel is intact.

6.10.2 SLIP-RING ASSEMBLY

The main purpose of the SLIP-RING ASSEMBLY is to provide an electrical path for the feed and switch signal return, between the Two-Block switch and the system computer.

It is unlikely that the slip-ring assembly should ever require repair or replacement. If such an event arises, however, both the upper and lower halves of the slip-ring assembly must be replaced at the same time.

Failure of the slip-ring assembly will most likely result in a continuous Two-Block alarm. For information on testing and checking the slip-ring assembly, refer to the Anti-Two-Block function in SECTION 7.

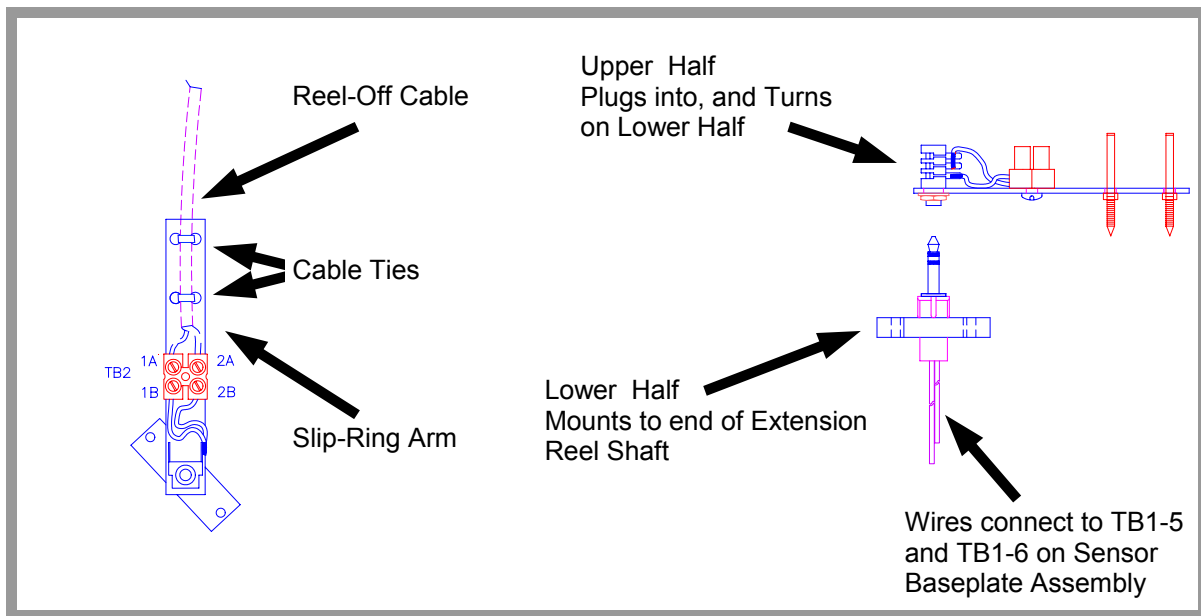

FIGURE 6.9 SLIP-RING ASSEMBLY

REMOVING THE SLIP-RING ASSEMBLY

1. Remove the extension reel cover.
2. Holding the reel-off cable on the arm of the slip-ring, cut the tie wraps.
3. Unscrew the reel-off cable from TB2 on the arm of the slip-ring.
4. Unscrew both Phillips screws that hold the lower half of the slip-ring on the shaft; remove the slip-ring.
5. Disconnect the two wires connecting the lower half of the slip-ring assembly at TB1-5 and TB1-6 on the sensor baseplate assembly.

INSTALLING THE SLIP-RING ASSEMBLY

The new SLIP-RING ASSEMBLY is pre-lubricated with grease. Do not wipe off lubrication.

1. Attach the brown slip-ring wire from the lower half of the new slip-ring to TB1-5 on the sensor baseplate assembly. Make sure that the brown signal wire is also correctly connected.
2. Attach the black (or white) slip-ring wire from the lower half of the new slip-ring to TB1-6 on the sensor baseplate assembly. Make sure that the black signal cable wire is also correctly connected.
3. Screw the bottom half of the slip-ring to the shaft with the two Phillips screws, making sure that wires exiting through the center of the shaft are not trapped.
4. Connect the extension reel-off cable to TB2 on the arm of the slip-ring. The braided shield connects to the slip-ring TB2 black wire and the center of the cable connects to the slip-ring TB2 brown wire.
5. Secure the extension reel-off cable to the arm of the slip-ring with two cable ties.
6. Ensure that the slip-ring is plugged in all the way.
7. Replace the extension reel cover.

6.10.3 SENSOR BASEPLATE ASSEMBLY

The SENSOR BASEPLATE ASSEMBLY supports both the extension and angle sensors and provides interconnection between the sensors, the Two-Block switch signal to the slip-ring, and the signal cable to the system computer.

Electrical or mechanical failure of either the angle sensor or the extension sensor potentiometers may not be field-repaired, since the angle sensor pendulum is factory set on the potentiometer shaft, and the extension potentiometer gear contains a protection clutch which is difficult to replace in the field. In the event of failure of either of these items, the whole sensor baseplate assembly must be replaced.

The terminal block (TB1), mounted on the assembly, provides wiring connection for all internal parts of the extension reel, and the signal cable connecting the reel to the system computer. Most electrical diagnoses of the boom sensors may be made at this terminal block.

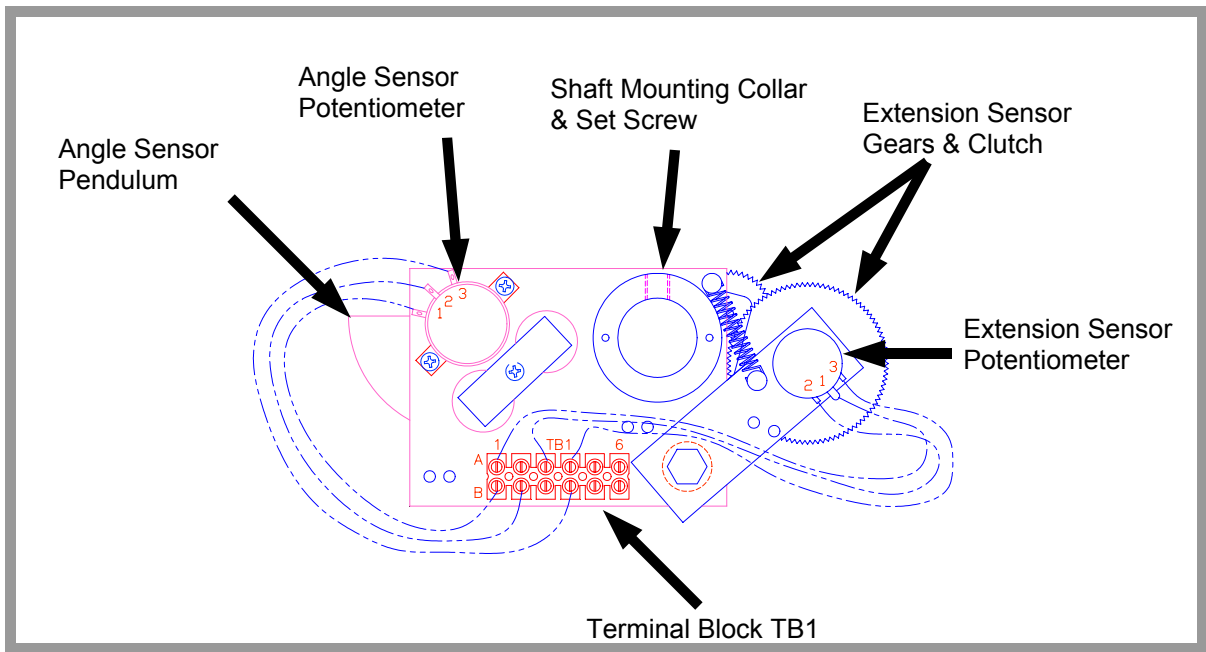

FIGURE 6.10 SENSOR BASEPLATE ASSEMBLY

REMOVING THE SENSOR ASSEMBLY

1. Remove the aluminum cover on the extension reel.
2. Unscrew the screws holding the slip-ring to the mounting ring of the SENSOR ASSEMBLY.
3. Disconnect the brown and black wires.
4. Disconnect the signal cable wires to terminal block TB1.
5. Using a 5/32" Allen wrench, loosen the set-screw that holds the baseplate on the shaft.
6. Remove the sensor assembly.

INSTALLING THE SENSOR ASSEMBLY

Place the boom in a horizontal position when installing the SENSOR ASSEMBLY.

1. Feed the wires coming out of the main shaft through the mounting collar on the sensor assembly.
2. While pulling both extension sensor gears out, against the spring, slide the sensor assembly onto the shaft until the top of the shaft aligns with the top of the mounting collar. Align the top edge of the assembly parallel with the boom.
3. Tighten the set-screw and release the gears allowing them to mesh with the extension reel spline. Route the wires to the terminal block and hook up the wires, as indicated below. Refer to Figure 6.10.

SENSOR ASSEMBLY TERMINAL BLOCK WIRING						
TERMINAL	TB1-1	TB1-2	TB1-3	TB1-4	TB1-5	TB1-6
WIRE COLOR	BLUE	GREEN	WHITE	RED	BROWN	BLACK
SIGNAL	SENSOR DRIVE -	ANGLE	EXTENSION	SENSOR DRIVE +	ATB-SIGNAL	ATB-FEED

4. Tuck the unconnected remaining yellow and orange wires down into the shaft.
5. Screw the slip-ring assembly to the baseplate of the sensor assembly.
6. Connect the brown wire on the slip-ring assembly to TB1-5; connect the black wire to TB1-6. Strip wires, if not already stripped.
7. **Note:** Ensure that the wires lay flat. Ensure that there will be enough space to allow the slip-ring arm to freely rotate.
8. Check the wiring and then follow the procedures to set up both the angle and extension sensors later in this section.

6.10.4 SIGNAL CABLE ASSEMBLY

The SIGNAL CABLE ASSEMBLY provides interconnection between the extension reel sensors, the Two-Block switch and the system computer.

REMOVING THE EXTENSION REEL FROM THE BOOM

1. Fully lower and retract the boom.
2. Disconnect the EXTENSION REEL CABLE from the Anti Two-Block switch.
3. Gripping the extension reel cable firmly, remove it from the tie-off post.
4. Maintain a firm hold on the extension reel cable as the cable unwinds back onto the reel.
5. Secure the end of the extension reel cable to prevent unwinding.
6. Disconnect the signal cable at the distal end.
7. Unbolt the extension reel from the crane with a wrench.

REMOVING THE SIGNAL CABLE FROM THE EXTENSION REEL

1. Remove the cover from the extension reel.
2. Remove the slip-ring on the baseplate of the sensor assembly.
3. Disconnect all wires from the sensor assembly **EXCEPT** for the 6 wires leading to the angle and extension sensor potentiometers.
4. To protect the sensors within the extension reel, use two screws to temporarily reattach the cover of the extension reel.
5. Turn over the extension reel with cover attached, exposing the back of the device.
6. With the wires still disconnected, pull the SIGNAL CABLE out of the main shaft in the center of the reel. This cable has a strain-relief encircled with an "O"-Ring, creating a tight fit that seals out water.

NOTE: If it is difficult to remove the cable, use the Insertion/Extraction tool from the **FRONT** of the extension reel to release the cable.

INSTALLING THE SIGNAL CABLE

1. Unpack the new SIGNAL CABLE and ensure that the "O"-ring on the strain-relief is greased.
2. With the back of the extension reel still exposed, insert the end of the signal cable with the "O"-ring into the mounting plate and down the shaft in the center of the reel.
3. Seat the strain-relief, with attached "O"-ring, as follows, using the tool provided in the kit.
4. Bend the cable to the side. Position the hollowed-out section of the tool on the strain-relief plug at the top of the shaft.
5. With a hammer, gently tap the top of the tool forcing the strain-relief into proper position in the shaft. Continue to tap gently until the strain-relief plug will go no further.
6. Turn over the extension reel and remove the cover.
7. Connect the wires to the terminal block on the baseplate, as indicated below.

SIGNAL CABLE TERMINAL BLOCK WIRING						
TERMINAL	TB1-1	TB1-2	TB1-3	TB1-4	TB1-5	TB1-6
WIRE COLOR	BLUE	GREEN	WHITE	RED	BROWN	BLACK
SIGNAL	SENSOR DRIVE -	ANGLE	EXTENSION	SENSOR DRIVE +	ATB-SIGNAL	ATB-FEED

8. Tuck the unconnected remaining yellow and orange wires down into the shaft.
9. Connect the brown wire from the slip-ring assembly to TB1-5; connect the black wire to TB1-6. Strip wires, if not already stripped.
10. Screw the slip-ring assembly to the baseplate of the sensor assembly.
11. **NOTE:** Ensure that the wires lay flat and toward the terminal connectors, as shown in Figure 6.1 on page 40. Ensure that there will be enough space to clear the wires when the arm of the slip-ring rotates.
12. Replace the cover on the extension reel; reinstall the extension reel.

SECTION 7 - ANTI TWO-BLOCK FUNCTION

7.1 ANTI TWO-BLOCK FUNCTION OVERVIEW..... 58-59

7.2 CHECKING THE EXTENSION REEL-OFF CABLE60

7.3 CHECKING THE ANTI TWO-BLOCK CIRCUIT 60-61

7.1 ANTI TWO-BLOCK FUNCTION OVERVIEW

This section describes fault diagnoses of the Anti Two-Block detection circuit. For details of function kickouts (including the Anti Two-Block kickout), refer to SECTION 8.

The computer supplies a protected positive feed to the Anti Two-Block switches at the boom/jib head via the extension reel signal cable, slip-ring, and extension reel-off cable. With the Anti Two-Block weight hanging freely on the switch(es), the switch contact is closed and the signal return to the computer is high (6.25 volts). When the weight is lifted by the hook block, the switch contact is opened, and the computer will sense a low signal input (0 volts) from the A2B signal return.

Since the computer checks the protected feed voltage internally, the system is capable of detecting a short circuit of the feed (or the A2B signal return when the switch is closed) to the crane chassis. Fault codes are defined in SECTION 2.

The Anti Two-Block detection circuit is probably the most susceptible part of the System, since it is carried through so many of the system components. Often, most problems with this circuit may be identified through inspection of cables, switches, and the extension reel. Damage to these parts may result in continuous or intermittent A2B alarms.

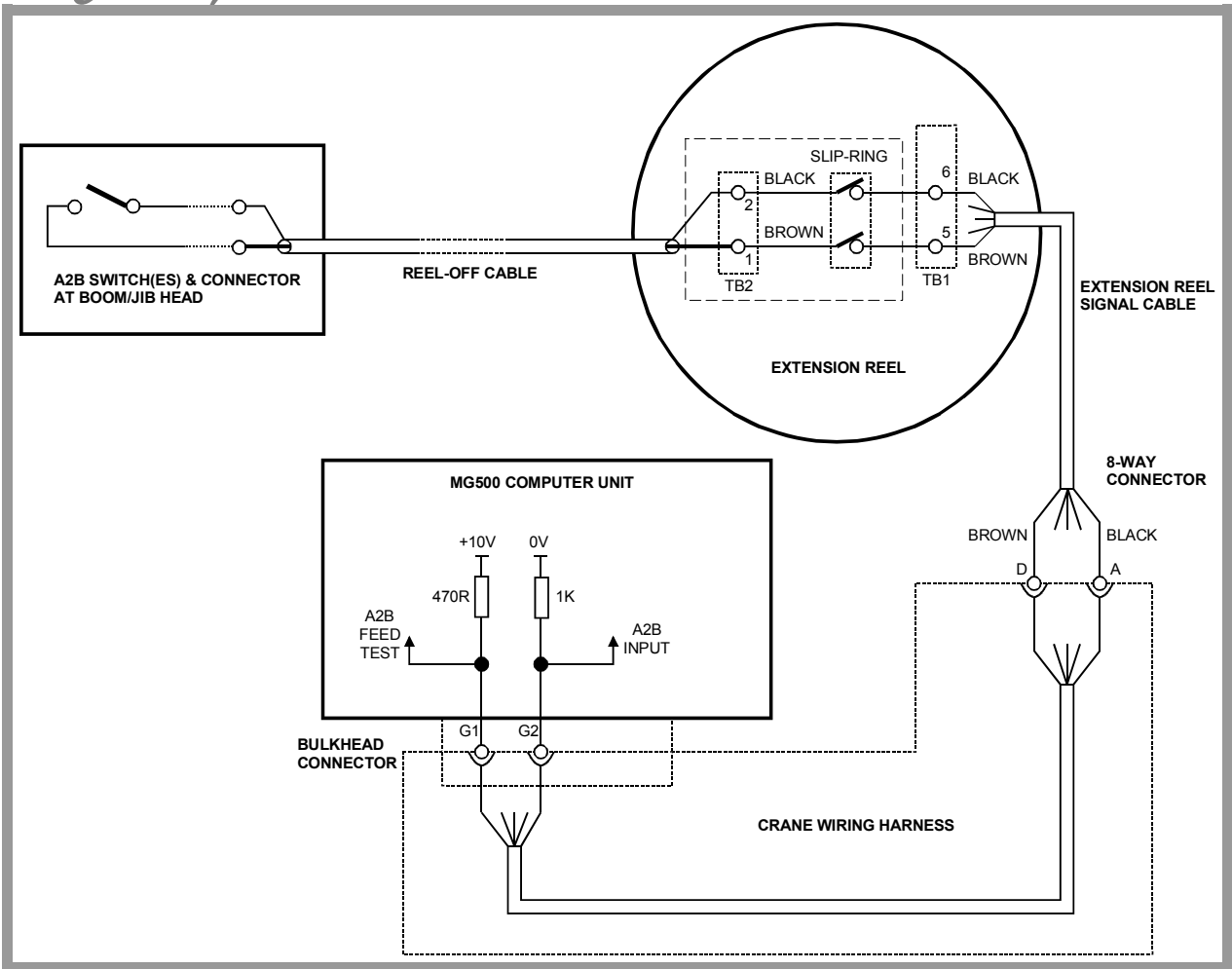

FIGURE 7.1 ANTI TWO-BLOCK FUNCTION SCHEMATIC

7.2 CHECKING THE EXTENSION REEL-OFF CABLE

The outer braid of the cable carries the Anti Two-Block feed to the switches. If the cable sheath is damaged, this may cause a short circuit to the boom/chassis. If this is the case, a fault code above “B 8” will be indicated (See SECTION 2.3.2). The same fault code will be indicated if the A2B switch is closed and the inner core of the cable is shorted to chassis at some point in the wiring.

- Carefully inspect the reel-off cable for wear.
- Check for signs of damage to the outer sheath of the cable.
- Check for any signs of severe “kinking” or crushing of the cable.

7.3 CHECKING THE ANTI TWO-BLOCK CIRCUIT

Before continuing, ensure that connectors are correctly connected to the A2B switches at the boom head/ jib.

1. Remove the extension reel cover.
2. Disconnect the slip-ring arm from the plug by pulling it away from the center of the reel.
3. Close the A2B switch at the boom head by suspending the weight from it or pulling on the chain.
4. Measure the resistance between TB2-1 & TB2-2 terminal connections on the sensor arm.

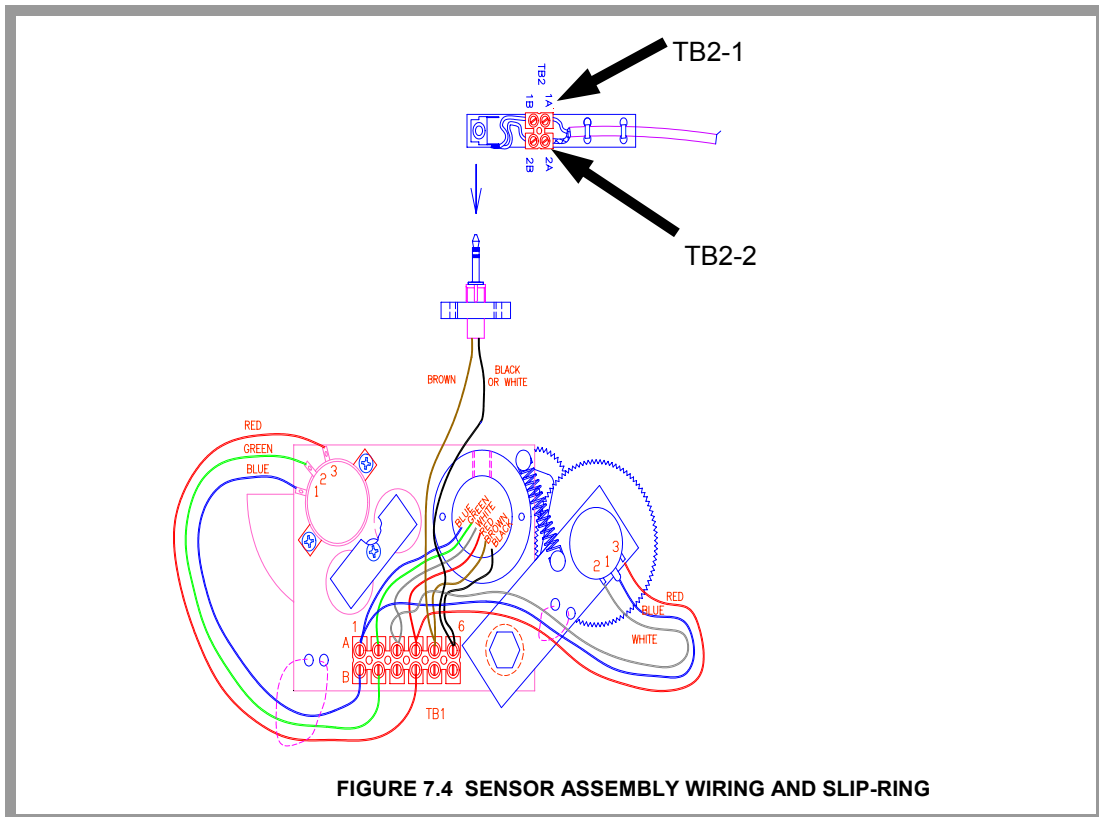

FIGURE 7.4 SENSOR ASSEMBLY WIRING AND SLIP-RING

5. With the A2B switch closed, the resistance should be less than 300 ohms. If not, this suggests that the reel-off cable, A2B switch, or one of the boom head connectors has an Open circuit.
6. Open the A2B switch at the boom head by lifting the weight.
7. Measure the resistance between TB2-1 & TB2-2 terminal connections on the sensor arm.
8. With the A2B switch open, the resistance should be greater than 10,000 ohms. If not, this suggests that the reel-off cable, A2B switch, or one of the boom head connectors has a short circuit.

SECTION 8 - POWER, KICKOUT & BOOM MODE OUTPUTS

8.1 POWER, KICKOUT & BOOM MODE OUTPUTS..... 62-63

This section provides schematic outlines of outputs from the computer and is provided for information only. Since most of these functions are contained within the computer design and crane wiring harness, only limited fault diagnosis may be carried out. The FKO fuse (FS2) is described in SECTION 3.

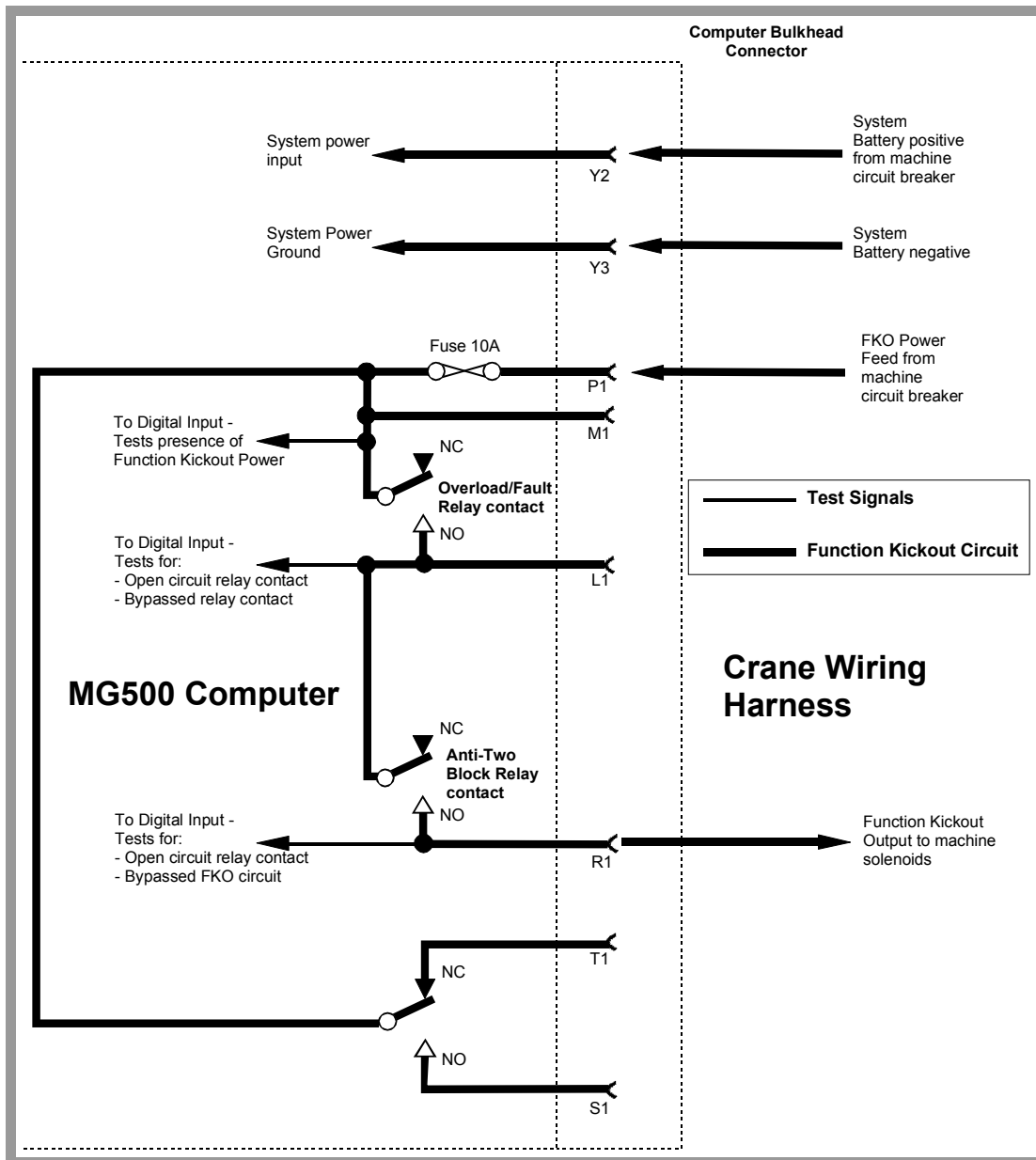

FIGURE 8.1 POWER, FUNCTION KICKOUT & BOOM MODE SCHEMATIC

SECTION 9 - SWING SENSOR

9.1 SWING SENSOR OVERVIEW65

9.2 CHECKING THE SWING SENSOR DRIVE VOLTAGE66

9.3 CHECKING THE SWING SENSOR OUTPUT VOLTAGE66

9.4 CHECKING THE SWING SENSOR RESISTANCE66

9.5 SWING SENSOR SETUP AND CHECKS.....67

 9.5.1 CHECKING AND SETTING ZERO67

 9.5.2 CHECKING AND SETTING DIRECTION67

9.1 SWING SENSOR OVERVIEW

The SWING SENSOR measures the angle of the upper structure of the crane relative to its carrier. This angle is then used to select capacity charts and operator swing alarms/working area alarms.

In the event that the swing sensor fails, the computer will be unable to select a valid capacity chart.

For fault diagnosis, the swing sensor may be accessed by removing the cover of the collector at the cranes swing center. See Figure 9.1 below.

For swing sensor replacement procedures, consult factory service.

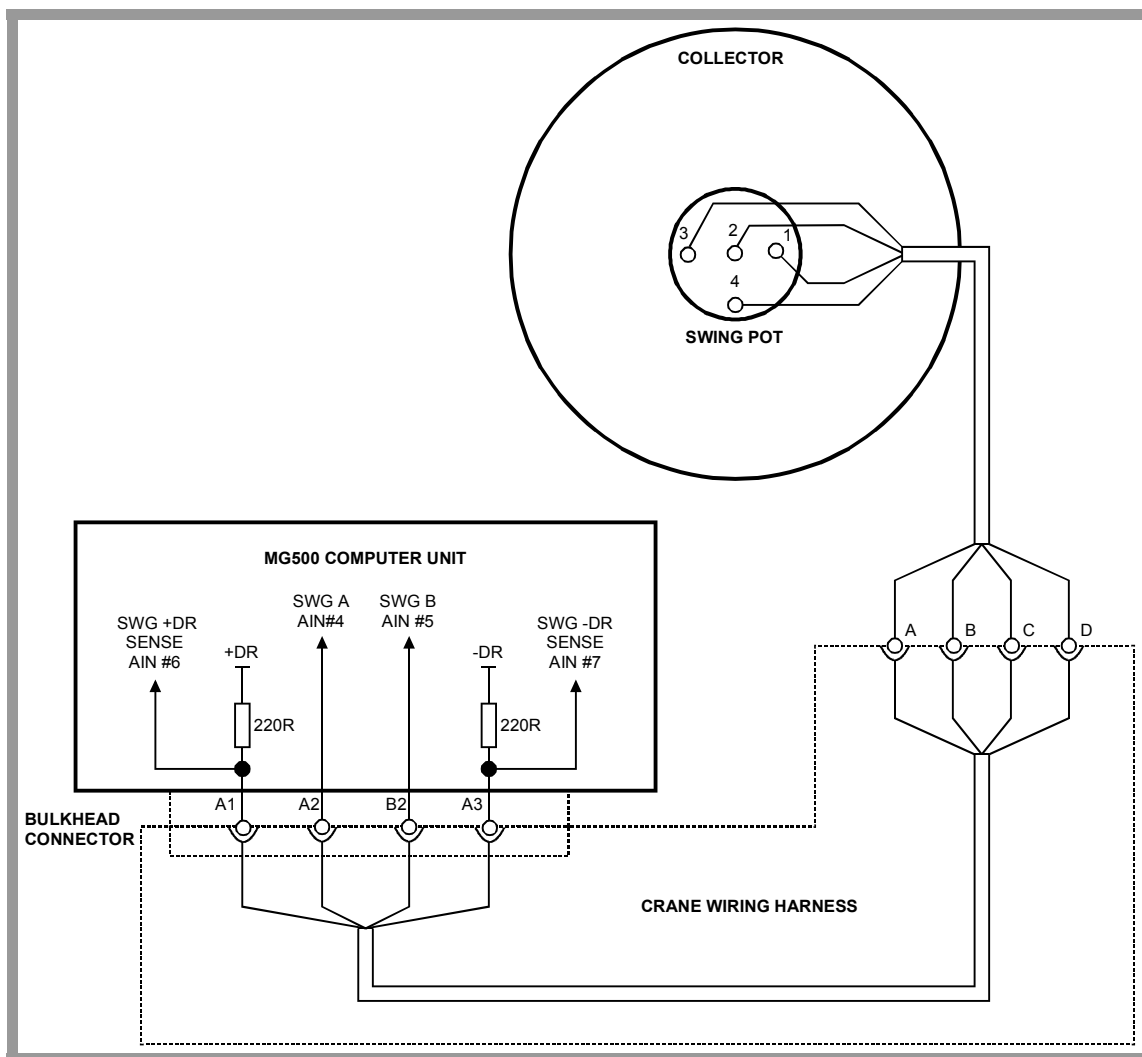

FIGURE 9.1 SWING SENSOR SCHEMATIC

9.2 CHECKING THE SWING SENSOR DRIVE VOLTAGE

1. Remove the collector ring cover to expose the swing sensor.
2. With the system power turned on, measure the voltage between terminal 1 of the swing sensor and crane ground. The voltage should be between 4.4 and 4.8 volts.
3. Measure the voltage between Terminal 3 of the swing sensor and crane ground. The voltage should be between 0.2 and 0.5 volts.

Voltages outside of those shown in steps 2 and 3 indicate a problem with the swing sensor or cabling connections. If voltages are incorrect, proceed to SECTION 9.4. If voltages are correct, proceed to SECTION 9.3.

9.3 CHECKING THE SWING SENSOR OUTPUT VOLTAGE

1. Remove the collector ring cover to expose the swing sensor.
2. With the system power turned on, measure the voltage between Terminal 2 of the swing sensor and crane ground. The voltage should be between 0.2 and 4.8 volts.
3. Measure the voltage between Terminal 4 of the swing sensor and crane ground. The voltage should be between 0.2 and 4.8 volts.

Voltages outside of those shown in Steps 2 and 3 indicate a problem with the swing sensor or cabling connections. If voltages are incorrect, proceed to SECTION 9.4.

9.4 CHECKING THE SWING SENSOR RESISTANCE

1. Disconnect the connector (behind the collector ring).
2. Measure the resistance between pins C and D of the connector on the swing sensor side. The resistance should be between 2200 and 2800 ohms.
3. Measure the resistance between pins A and B of the connector on the swing sensor side. The resistance should be between 1800 and 2300 ohms.

NOTE: Resistances outside of those shown in Steps 2 and 3 indicate a problem with the swing sensor or associated cable connections. If resistances are incorrect, replace the swing sensor and its cable.

9.5 SWING SENSOR SETUP AND CHECKS

The following procedures may be used to check or setup the SWING SENSOR. Only two setup operations are required (ZERO and DIRECTION). Unlike other system sensors, the swing sensor requires no span calibration to operate. Span is automatically calculated by the computer.

9.5.1 CHECKING AND SETTING ZERO

The 0° (zero) angle of the upper structure should be set with the house-lock engaged over front for all types of cranes. Before continuing, ensure that the upper structure is positioned over FRONT and the the house-lock is engaged.

1. Enter the CALIBRATION MODE at the display console. (Refer to Calibration Mode Entry, page 39.)
- 2.
3. Select Command 07, SWING SENSOR
4. Check that the angle value displayed is between -0.5° and + 0.5°. If not, reset the zero by pressing the zero key.

9.5.2 CHECKING AND SETTING DIRECTION

1. Enter the CALIBRATION MODE at the display console.(Refer to Calibration Mode Entry, page 39.)
2. Select Command 04, SWING SENSOR
3. Remove the house-lock and swing to the right. Check that the angle value displayed increases from zero. If not, the displayed value will immediately jump to over 350° and continue counting down as the crane upper is swung to the right. If this is the case, press the direction key to reverse the calibrated direction of the sensor.



GREER COMPANY

1918 East Glenwood Place
Santa Ana, CA 92705
Telephone: (714) 259-9702
Fax: (714) 259-7626