

To learn more about this model, call 414-764-9200 or visit giuffre.com today!

**NATIONAL
CRANE®**
by **Manitowoc**

NTC55 Product Guide

ASME B30.5 • Imperial 85%



Features

- 49,9 t (55 USt) capacity at 2,44 m (8 ft)
- 39,01 m (128 ft) five-section, full-power boom
- Four-position outrigger settings
- Hydraulically removable counterweight system with multiple configurations
- Hydraulically tilting operator cab



AVAILABLE AT:

GIUFFRE.COM

GIUFFRE BROS CRANES INC.

6635 SOUTH 13TH ST. - MILWAUKEE, WI 53221
414-764-9200 • 877-321-3710

To learn more about this model, call 414-764-9200 or visit giuffre.com today!

NATIONAL CRANE NTC55

The roadability of a boom truck combined with the capacity and performance of a truck crane.

Features

> **Extreme versatility and strength**

With four outrigger configurations, four counterweight configurations, a premium commercial truck chassis for superior roading performance, and a 49,9 t (55 US_t) capacity, the NTC55 is the ideal crane for your fleet.

> **Five-section boom**

The NTC55 is equipped with a 39,0 m (128 ft) boom. An optional 7,9 m (26 ft) fixed length offsettable jib and a 7,9 m – 13,7 m (26 ft – 45 ft) two-section offsettable manual extension is available.

> **Operator-focused design**

The NTC55 is designed specifically with the operator in mind, with up to 20° cab tilt, a graphical RCL with integrated control system, and lighter polymeric outrigger floats for easy setup.

> **Four-position outriggers**

Equipped with left and right ground-level and in-cab CANbus outrigger controls, the NTC55's outriggers allow for quick and easy crane setup. An outrigger beam position system aids the operator in selecting the right load chart based on the crane's outrigger footprint. The front outrigger box has an X-shaped footprint that eliminates the need for a single front outrigger. Load charts are available for 100%, 75%, 50% and fully retracted spans.

> **Options and Lift Solutions**

- Hydraulic hose reels
- Factory-installed toolbox options
- Wireless anti-two-block system



To learn more about this model, call 414-764-9200 or visit giuffre.com today!

GIUFFRE.COM

Jobsite benefits

- Truck crane replacement with modern features.
 - 5,5 m – 10,4 m (18 ft – 34 ft) longer main boom length than competitive 36,3 t (40 USt) truck cranes
 - Four outrigger positions, including a unique 6,1 m (20 ft) span for tight operating spaces (similar to 40 USt truck cranes)
 - Rock-solid operating performance with less carrier flex and twist than an average boom truck
 - Hydraulically self-removable counterweight with multiple slabs for easy roading
- Simpler, smoother and smarter operation.
 - Graphical RCL for easy setup
 - Class-leading features such as adjustable joystick speeds, on-board diagnostics, and service capabilities without the need for a laptop
 - Offsettable jib options
- Enhanced comfort, access and egress and setup.
 - Comfort of a commercial truck chassis from leading manufacturers
 - 20° hydraulically tilting, ergonomic operator cab
 - Strong aluminum decking with multiple ladders for easy access
 - Lighter polymeric operator floats that are easy to use and less prone to theft when on the job



Manitowoc Crane Care when you need it.
The assurance of the world's most advanced crane service and support to get you back to work fast.



Manitowoc Finance helps you get right to work generating profits for your business.
Financial tools that help you capitalize on opportunity with solutions that fit your needs.



AVAILABLE AT:

GIUFFRE.COM

GIUFFRE BROS CRANES INC.

6635 SOUTH 13TH ST. - MILWAUKEE, WI 53221
414-764-9200 • 877-321-3710

To learn more about this model, call 414-764-9200 or visit giuffre.com today!

Contents

Dimensions and weights	5
Mounting configurations	7
Working range	9
Load charts	10
Specifications	37
Symbols glossary	41



AVAILABLE AT:

GIUFFRE.COM

GIUFFRE BROS CRANES INC.

6635 SOUTH 13TH ST. - MILWAUKEE, WI 53221
414-764-9200 • 877-321-3710

To learn more about this model, call 414-764-9200 or visit giuffre.com today!

Dimensions

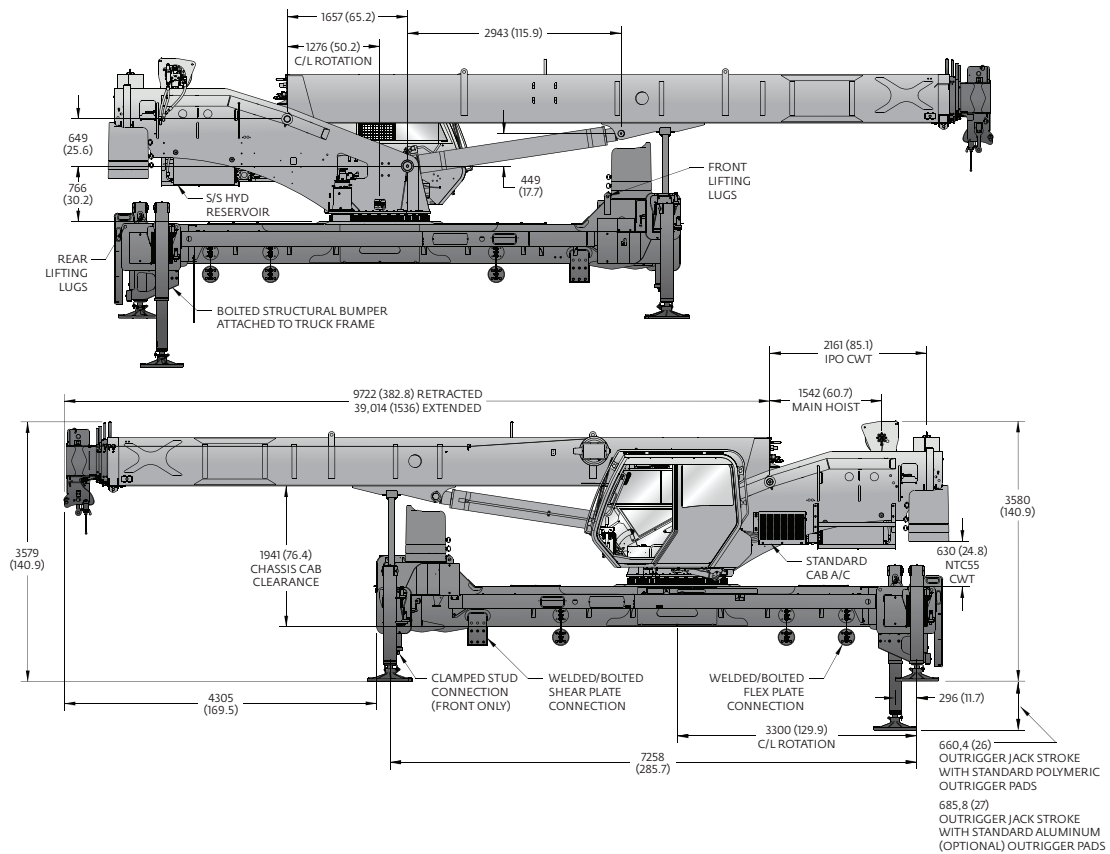

Dimensions are in mm (in) unless otherwise specified

National Crane NTC55

5



AVAILABLE AT:

GIUFFRE.COM

GIUFFRE BROS CRANES INC.

6635 SOUTH 13TH ST. - MILWAUKEE, WI 53221
414-764-9200 • 877-321-3710

To learn more about this model, call 414-764-9200 or visit giuffre.com today!

Dimensions

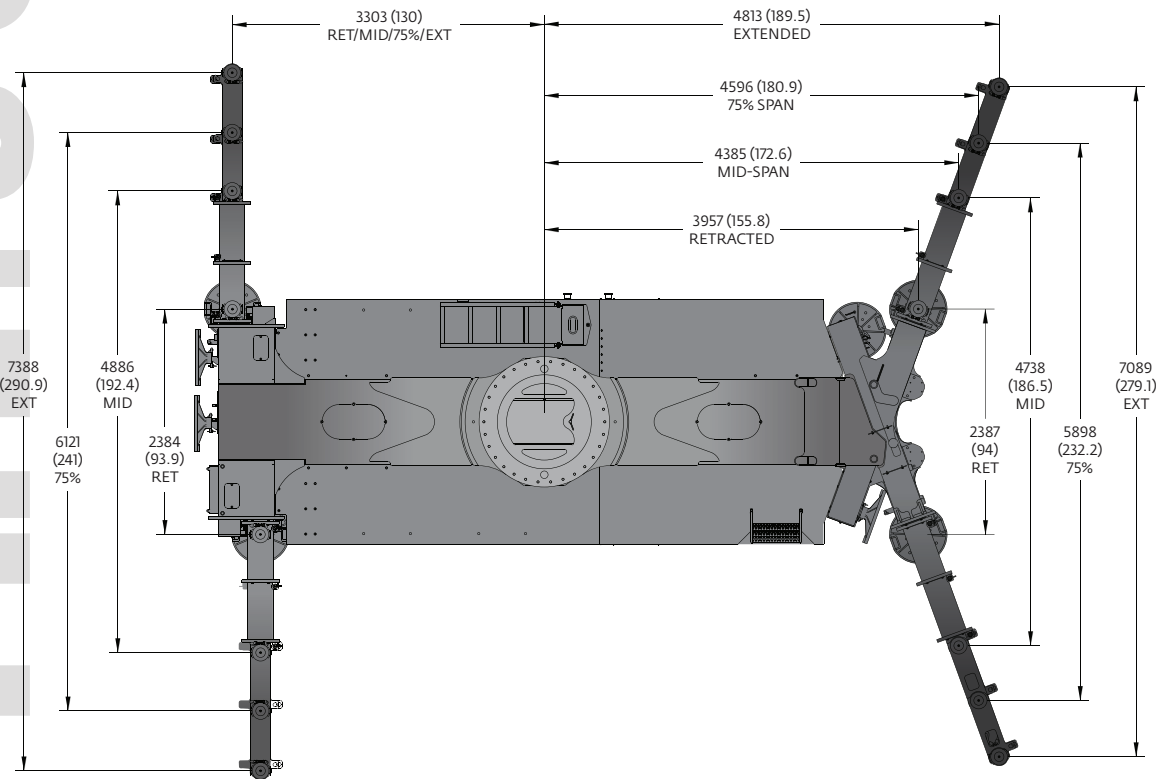

Dimensions are in mm (in) unless otherwise specified

Weight and CG Estimates

Configuration	Horizontal CG mm (in)	Weight w/ Fluids kg (lbs)	CWT Pinned (# slabs)	CWT Stowed (# slabs)
NTC55128	616 (24.3)	22 067 (48,650)	3	0

Mounting configurations

The configurations are based on the NTC55 with an 85% stability factor. The complete unit must be installed in accordance with factory requirements and a test performed to determine actual stability and counterweight requirements since individual truck chassis vary.

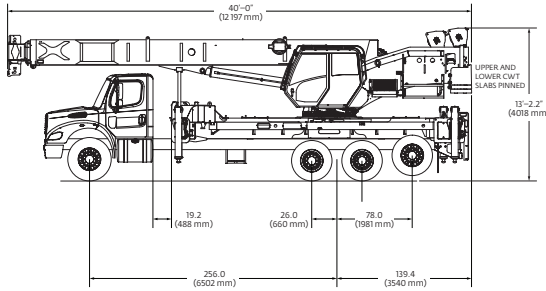

NTC55 Series Minimum Truck Specification

Working area: 360°
 Gross Axle Weight Rating Front: 9072 kg (20,000 lb)
 Gross Axle Weight Rating Rear: 18 144 kg (40,000 lb)
 Gross Axle Weight Rating Tag: 5987 kg (13,200 lb)
 Wheelbase: 650 cm (256 in)
 Cab to Axle/trunnion (CA/CT): 488 cm (192 in)
 Frame Strength: 785 Mpa (110,000 PSI)
 Frame Section Modulus (SM), front axle to end of AF: 327 cm³ (20 in³)
 Stability Weight, Front: 4355 kg (9600 lb) minimum
 Stability Weight, Rear: 4609 kg (10,160 lb) minimum
 NOTE: Estimated axle scale weights prior to installation of crane assembly for 85% stability. This configuration does not meet Federal Bridge Law.

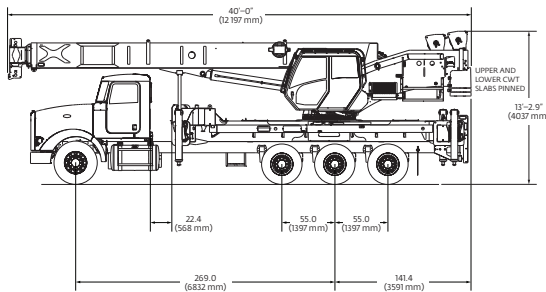

NTC55 Recommended 4 Axle Truck Specification

Working area: 360°
 Gross Axle Weight Rating Front: 9072 kg (20,000 lb)
 Gross Axle Weight Rating Rear: 29 937 kg (66,000 lb)
 Wheelbase: 683 cm (269 in)
 Cab to Axle/trunnion (CA/CT): 488 cm (192 in)
 Frame Strength: 785 Mpa (110,000 PSI)
 Frame Section Modulus (SM), front axle to end of AF: 327 cm³ (20 in³)
 Stability Weight, Front: 4445 kg (9800 lb) minimum
 Stability Weight, Rear: 4899 kg (10,800 lb) minimum
 NOTE: Estimated axle scale weights prior to installation of crane assembly for 85% stability. This configuration does not meet Federal Bridge Law.

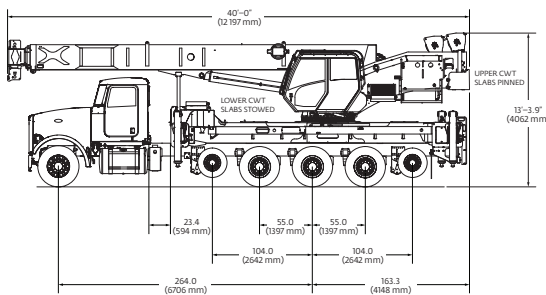

NTC55 Recommended 6 Axle Truck Specification

Working area: 360°
 Gross Axle Weight Rating Front: 9072 kg (20,000 lb)
 Gross Vehicle Weight Rating Pusher: 3629 kg (8000 lb)
 Gross Axle Weight Rating Rear: 29 937 kg (66,000 lb)
 Gross Axle Weight Rating Tag: 3629 kg (8000 lb)
 Wheelbase: 671 cm (264 in)
 Cab to Axle/trunnion (CA/CT): 475 cm (187 in)
 Frame Strength: 785 Mpa (110,000 PSI)
 Frame Section Modulus (SM), front axle to end of AF: 327 cm³ (20 in³)
 Stability Weight, Front: 4445 kg (9800 lb) minimum
 Stability Weight, Rear: 5896 kg (13,000 lb) minimum
 NOTE: Estimated axle scale weights prior to installation of crane assembly for 85% stability. This configuration does not meet Federal Bridge Law.

Mounting configurations

Minimum truck requirements

Many factors must be considered in the selection of proper truck for an NTC55 crane. Items which must be considered are:

1. Axle Rating. Axle ratings are determined by the axles, tires, rims, springs, brakes, steering and frame strength of the truck. If any one of these components is below the required rating, the gross axle rating is reduced to its weakest component value.

2. Wheelbase (WB), Cab-to-Trunnion (CT) and Bare Chassis Weight. The wheelbase, CT and chassis weights shown are required so the basic NTC55 can be legally driven in most states and meet stability requirements. The dimensions given assume the sub-base is installed properly behind the truck cab. If exhaust stacks, transmission protrusions, etc., do not allow a close installation to the cab, the WB and CT dimensions must be increased. Refer to the Mounting Configuration pages for additional information.

3. Truck Frame. Try to select a truck frame that will minimize or eliminate frame reinforcement or extension of the after frame (AF). Many frames are available that have the necessary after frame (AF) section modulus (SM) and resistance to bending moment (RBM)

so that reinforcing is not required. The front hydraulic jack is used for a 360° working range around the truck. The frame under the cab through the front suspension must have the minimum S.M. and RBM because reinforcing through the front suspension is often difficult because of engine, radiator mounts and steering mechanics. See "Truck Requirements" and "Frame Strength" pages for the necessary section modulus and resistance to bending moment values. Integral extended front frame rails are required for front center stabilizer installation.

4. Additional Equipment. In addition to the axle ratings, wheelbase, cab-to-axle requirements and frame, it is recommended that the truck is equipped with electronic engine control, increased cooling and a transmission with a PTO opening available with an extra heavy duty PTO. A conventional cab truck should be used for standard crane mounts.

5. Neutral Start Switch. The chassis must be equipped with a switch that prevents operation of the engine starter when the transmission is in gear.

Notes:

- Gross Vehicle Weight Rating (GVWR) is dependent on all components of the vehicle (axles, tires, springs, frame, etc.) meeting manufacturers' recommendations; always specify GVWR when purchasing trucks
- Diesel engines require a variable speed governor for smooth crane operation; electronic fuel injection requires EET engine remote throttle

- All mounting data is based on a National Crane NTC55 with an 85% stability factor
- The complete unit must be installed in accordance with factory requirements, and a test performed to determine actual stability and counterweight requirements per SAE J765; contact the factory for details

To learn more about this model, call 414-764-9200 or visit giuffre.com today!

Working range

 39,01 m
(128 ft)

 7,9 m – 13,7 m
(26ft – 45 ft)

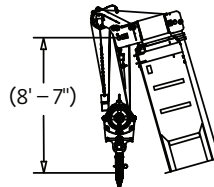
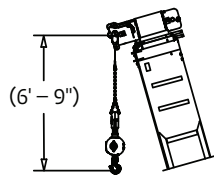
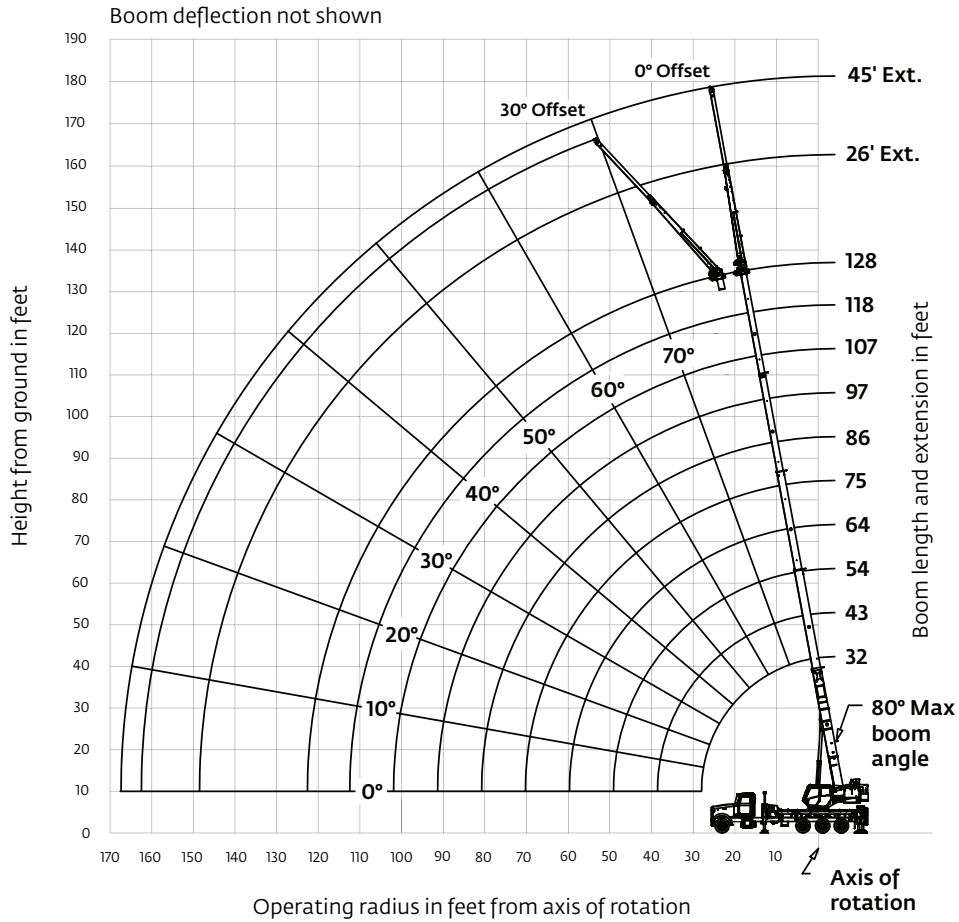

Dimensions are for largest furnished hookblock and headache ball with anti-two-block activated.

*This drawing shows the physical reach of the machine. Always refer to load chart to see which portions of this diagram are valid for the specific machine configuration and where the loads are structurally or stability limited.

THIS CHART IS ONLY A GUIDE AND SHOULD NOT BE USED TO OPERATE THE CRANE.

The individual crane's load chart, operating instructions and other instructional plates must be read and understood prior to operating the crane.

National Crane NTC55

9



AVAILABLE AT:

GIUFFRE.COM

GIUFFRE BROS CRANES INC.

6635 SOUTH 13TH ST. - MILWAUKEE, WI 53221
414-764-9200 • 877-321-3710

To learn more about this model, call 414-764-9200 or visit giuffre.com today!

Load charts

 9,7 m – 39,0 m
(31.7 ft – 128 ft)

 2494 kg
(5500 lb)

 100%

 360°



 Pounds

Radius in feet	#0001									
	Main Boom Length in Feet									
	31.7	43-A	54-B	64-C	75-D	86-E	97-F	107-G	118-H	128
8	110,000 (68.1)	—	—	—	—	—	—	—	—	—
10	92,300 (64)	39,200 (71.6)	39,700 (75.6)	—	—	—	—	—	—	—
12	81,200 (59.8)	39,200 (68.7)	39,700 (73.4)	40,300 (76.4)	34,100 (78.7)	—	—	—	—	—
15	65,200 (53.1)	39,200 (64.4)	39,700 (70.1)	40,300 (73.5)	34,100 (76.4)	22,650 (78.3)	—	—	—	—
20	47,650 (40.3)	39,200 (56.7)	39,700 (64.4)	40,300 (68.8)	34,100 (72.5)	22,650 (75)	17,800 (77.1)	14,700 (78.6)	—	—
25	31,650 (21.8)	37,600 (47.5)	38,000 (58)	37,150 (63.9)	30,100 (68.4)	22,650 (71.5)	17,800 (74.2)	14,700 (76.1)	12,900 (77.8)	9600 (78.9)
30	—	30,050 (37.3)	30,450 (51.3)	30,700 (58.6)	27,100 (64.2)	20,400 (68)	17,800 (71.2)	14,700 (73.5)	12,900 (75.6)	9600 (76.9)
35	—	22,300 (23.6)	24,950 (43.9)	25,150 (53.1)	24,600 (59.8)	18,500 (64.3)	16,300 (68)	14,700 (70.8)	12,900 (73.2)	9600 (74.8)
40	—	—	20,450 (35.2)	20,700 (47)	20,850 (55.1)	17,050 (60.5)	15,100 (64.7)	13,650 (68)	12,050 (70.8)	9600 (72.7)
45	—	—	*16,400 (24)	16,700 (40.3)	16,850 (50)	15,800 (56.5)	14,000 (61.5)	12,550 (65)	11,300 (68.2)	9600 (70.6)
50	—	—	—	13,700 (32.4)	13,900 (44.6)	14,000 (52.3)	12,850 (58)	11,750 (62)	10,650 (65.8)	9600 (68.4)
55	—	—	—	11,450 (22.2)	11,600 (38.6)	11,700 (47.8)	11,750 (54.4)	10,950 (59.2)	10,000 (63.2)	8750 (65.9)
60	—	—	—	—	9860 (32.4)	9980 (43.3)	10,050 (50.8)	10,100 (56)	9400 (60.4)	7850 (63.3)
65	—	—	—	—	8380 (23.9)	8510 (37.9)	8590 (46.6)	8640 (52.4)	8680 (57.5)	7000 (60.6)
70	—	—	—	—	*4650 (9.2)	7290 (31.8)	7370 (42.1)	7420 (48.7)	7460 (54.3)	6300 (57.9)
75	—	—	—	—	—	6260 (24.3)	6350 (37.2)	6400 (44.7)	6440 (51)	5700 (55)
80	—	—	—	—	—	*4400 (12.8)	5470 (31.6)	5520 (40.5)	5560 (47.5)	5150 (52.1)
85	—	—	—	—	—	—	4710 (24.8)	4770 (35.8)	4810 (43.8)	4650 (49)
90	—	—	—	—	—	—	*3850 (15.3)	4110 (30.4)	4150 (39.8)	4150 (45.7)
95	—	—	—	—	—	—	—	3530 (24)	3570 (35.4)	3600 (42.2)
100	—	—	—	—	—	—	—	*2800 (14.9)	3060 (30.5)	3090 (38.4)
105	—	—	—	—	—	—	—	—	2600 (24.6)	2630 (34.2)
110	—	—	—	—	—	—	—	—	2180 (16.8)	2220 (29.5)
115	—	—	—	—	—	—	—	—	—	1850 (23.7)
120	—	—	—	—	—	—	—	—	—	*1100 (15.8)
Minimum boom angle (°) for indicated length (no load)							0	5	8	10
Maximum boom length (ft) at 0° (no load)							97			

NOTE: () Boom angles are in degrees.
*Loads are structurally limited.
#RCL operating code. Refer to RCL manual for operating instructions.

Boom Angle	Lifting Capacities at Zero Degree Boom Angle									
	Main Boom Length in Feet									
	31.7	43-A	54-B	64-C	75-D	86-E				
0°	12,900 (27.6)	7600 (38.8)	4850 (49.8)	3700 (59.8)	2200	1150 (81.8)	—	—	—	—

NOTE: () Reference radii in feet. 80095948

THIS CHART IS ONLY A GUIDE AND SHOULD NOT BE USED TO OPERATE THE CRANE.
The individual crane's load chart, operating instructions and other instructional plates must be read and understood prior to operating the crane.

Load charts

9,7 m – 39,0 m (31.7 ft – 128 ft)
 Stowed
 2494 kg (5500 lb)
 100%
 360°

Pounds

Radius in feet	#0002									
	Main Boom Length in Feet									
	31.7	43-A	54-B	64-C	75-D	86-E	97-F	107-G	118-H	128
8	108,500 (68.1)	—	—	—	—	—	—	—	—	—
10	91,150 (64)	38,400 (71.6)	39,100 (75.6)	—	—	—	—	—	—	—
12	80,050 (59.8)	38,400 (68.7)	39,100 (73.4)	39,800 (76.4)	33,650 (78.7)	—	—	—	—	—
15	64,050 (53.1)	38,400 (64.4)	39,100 (70.1)	39,800 (73.5)	33,650 (76.4)	22,250 (78.3)	—	—	—	—
20	46,500 (40.3)	38,400 (56.7)	39,100 (64.4)	39,800 (68.8)	33,650 (72.5)	22,250 (75)	17,450 (77.1)	14,400 (78.6)	—	—
25	30,500 (21.8)	36,800 (47.5)	37,400 (58)	36,650 (63.9)	29,650 (68.4)	22,250 (71.5)	17,450 (74.2)	14,400 (76.1)	12,600 (77.8)	9350 (78.9)
30	—	29,250 (37.3)	29,850 (51.3)	30,200 (58.6)	26,650 (64.2)	20,000 (68)	17,450 (71.2)	14,400 (73.5)	12,600 (75.6)	9350 (76.9)
35	—	21,500 (23.6)	24,350 (43.9)	24,650 (53.1)	24,150 (59.8)	18,100 (64.3)	15,950 (68)	14,400 (70.8)	12,600 (73.2)	9350 (74.8)
40	—	—	19,850 (35.2)	20,200 (47)	20,400 (55.1)	16,650 (60.5)	14,750 (64.7)	13,350 (68)	11,750 (70.8)	9350 (72.7)
45	—	—	*15,800 (24)	16,200 (40.3)	16,400 (50)	15,400 (56.5)	13,650 (61.5)	12,250 (65)	11,000 (68.2)	9350 (70.6)
50	—	—	—	13,200 (32.4)	13,450 (44.6)	13,600 (52.3)	12,500 (58)	11,450 (62)	10,350 (65.8)	9350 (68.4)
55	—	—	—	10,950 (22.2)	11,150 (38.6)	11,300 (47.8)	11,400 (54.4)	10,650 (59.2)	9700 (63.2)	8500 (65.9)
60	—	—	—	—	9410 (32.4)	9580 (43.3)	9700 (50.8)	9800 (56)	9100 (60.4)	7600 (63.3)
65	—	—	—	—	7930 (23.9)	8110 (37.9)	8240 (46.6)	8340 (52.4)	8380 (57.5)	6750 (60.6)
70	—	—	—	—	*4200 (9.2)	6890 (31.8)	7020 (42.1)	7120 (48.7)	7160 (54.3)	6050 (57.9)
75	—	—	—	—	—	5860 (24.3)	6000 (37.2)	6100 (44.7)	6140 (51)	5450 (55)
80	—	—	—	—	—	*4000 (12.8)	5120 (31.6)	5220 (40.5)	5260 (47.5)	4900 (52.1)
85	—	—	—	—	—	—	4360 (24.8)	4470 (35.8)	4510 (43.8)	4400 (49)
90	—	—	—	—	—	—	*3500 (15.3)	3810 (30.4)	3850 (39.8)	3900 (45.7)
95	—	—	—	—	—	—	—	3230 (24)	3270 (35.4)	3350 (42.2)
100	—	—	—	—	—	—	—	*2500 (14.9)	2760 (30.5)	2840 (38.4)
105	—	—	—	—	—	—	—	—	2300 (24.6)	2380 (34.2)
110	—	—	—	—	—	—	—	—	1880 (16.8)	1970 (29.5)
115	—	—	—	—	—	—	—	—	—	1600 (23.7)
120	—	—	—	—	—	—	—	—	—	*850 (15.8)
Minimum boom angle (°) for indicated length (no load)							0	5	8	10
Maximum boom length (ft) at 0° (no load)							97			

NOTE: () Boom angles are in degrees.
 *Loads are structurally limited.
 #RCL operating code. Refer to RCL manual for operating instructions.

Boom Angle	Lifting Capacities at Zero Degree Boom Angle									
	Main Boom Length in Feet									
	31.7	43-A	54-B	64-C	75-D	86-E				
0°	11,750 (27.6)	6800 (38.8)	4250 (49.8)	3200 (59.8)	1750 (70.8)	750 (81.8)	—	—	—	—

NOTE: () Reference radii in feet. 80095949

THIS CHART IS ONLY A GUIDE AND SHOULD NOT BE USED TO OPERATE THE CRANE.
 The individual crane's load chart, operating instructions and other instructional plates must be read and understood prior to operating the crane.

Load charts

 9,7 m – 39,0 m
(31.7 ft – 128 ft)

 2494 kg
(5500 lb)

 100%

 Over Rear



 Pounds

Radius in feet	#0003									
	Main Boom Length in Feet									
	31.7	43-A	54-B	64-C	75-D	86-E	97-F	107-G	118-H	128
8	110,000 (68.1)	—	—	—	—	—	—	—	—	—
10	92,300 (64)	39,200 (71.6)	39,700 (75.6)	—	—	—	—	—	—	—
12	81,200 (59.8)	39,200 (68.7)	39,700 (73.4)	40,300 (76.4)	34,100 (78.7)	—	—	—	—	—
15	65,200 (53.1)	39,200 (64.4)	39,700 (70.1)	40,300 (73.5)	34,100 (76.4)	22,650 (78.3)	—	—	—	—
20	47,650 (40.3)	39,200 (56.7)	39,700 (64.4)	40,300 (68.8)	34,100 (72.5)	22,650 (75)	17,800 (77.1)	14,700 (78.6)	—	—
25	31,650 (21.8)	37,600 (47.5)	38,000 (58)	37,150 (63.9)	30,100 (68.4)	22,650 (71.5)	17,800 (74.2)	14,700 (76.1)	12,900 (77.8)	9600 (78.9)
30	—	30,050 (37.3)	30,450 (51.3)	30,700 (58.6)	27,100 (64.2)	20,400 (68)	17,800 (71.2)	14,700 (73.5)	12,900 (75.6)	9600 (76.9)
35	—	22,300 (23.6)	24,950 (43.9)	25,150 (53.1)	24,600 (59.8)	18,500 (64.3)	16,300 (68)	14,700 (70.8)	12,900 (73.2)	9600 (74.8)
40	—	—	20,800 (35.2)	21,050 (47)	21,250 (55.1)	17,050 (60.5)	15,100 (64.7)	13,650 (68)	12,050 (70.8)	9600 (72.7)
45	—	—	16,400 (24)	17,850 (40.3)	18,050 (50)	15,800 (56.5)	14,000 (61.5)	12,550 (65)	11,300 (68.2)	9600 (70.6)
50	—	—	—	15,250 (32.4)	15,400 (44.6)	14,600 (52.3)	12,850 (58)	11,750 (62)	10,650 (65.8)	9600 (68.4)
55	—	—	—	*11,900 (22.2)	13,050 (38.6)	13,150 (47.8)	12,000 (54.4)	10,950 (59.2)	10,000 (63.2)	8,750 (65.9)
60	—	—	—	—	11,200 (32.4)	11,250 (43.3)	11,250 (50.8)	10,300 (56)	9400 (60.4)	7850 (63.3)
65	—	—	—	—	9660 (23.9)	9780 (37.9)	9860 (46.6)	9700 (52.4)	8850 (57.5)	7000 (60.6)
70	—	—	—	—	*4650 (9.2)	8490 (31.8)	8570 (42.1)	8620 (48.7)	8400 (54.3)	6300 (57.9)
75	—	—	—	—	—	7390 (24.3)	7470 (37.2)	7520 (44.7)	7560 (51)	5700 (55)
80	—	—	—	—	—	*4400 (12.8)	6540 (31.6)	6590 (40.5)	6630 (47.5)	5150 (52.1)
85	—	—	—	—	—	—	5720 (24.8)	5780 (35.8)	5820 (43.8)	4650 (49)
90	—	—	—	—	—	—	*3850 (15.3)	5070 (30.4)	5110 (39.8)	4150 (45.7)
95	—	—	—	—	—	—	—	4440 (24)	4480 (35.4)	3700 (42.2)
100	—	—	—	—	—	—	—	*2800 (14.9)	3930 (30.5)	3300 (38.4)
105	—	—	—	—	—	—	—	—	3430 (24.6)	3000 (34.2)
110	—	—	—	—	—	—	—	—	*2400 (16.8)	2650 (29.5)
115	—	—	—	—	—	—	—	—	—	1900 (23.7)
120	—	—	—	—	—	—	—	—	—	1100 (15.8)
Minimum boom angle (°) for indicated length (no load)							0	5	8	10
Maximum boom length (ft) at 0° (no load)							97			

NOTE: () Boom angles are in degrees.
*Loads are structurally limited.
#RCL operating code. Refer to RCL manual for operating instructions.

Boom Angle	Lifting Capacities at Zero Degree Boom Angle									
	Main Boom Length in Feet									
	31.7	43-A	54-B	64-C	75-D	86-E				
0°	12,900 (27.6)	7600 (38.8)	4850 (49.8)	3700 (59.8)	2200 (70.8)	1150 (81.8)	—	—	—	—

NOTE: () Reference radii in feet. 80095952

THIS CHART IS ONLY A GUIDE AND SHOULD NOT BE USED TO OPERATE THE CRANE.
The individual crane's load chart, operating instructions and other instructional plates must be read and understood prior to operating the crane.

Load charts

9,7 m – 39,0 m (31.7 ft – 128 ft)
 Stowed
 2494 kg (5500 lb)
 100%
 Over Rear

Pounds

Radius in feet	#0004									
	Main Boom Length in Feet									
	31.7	43-A	54-B	64-C	75-D	86-E	97-F	107-G	118-H	128
8	108,500 (68.1)	—	—	—	—	—	—	—	—	—
10	91,150 (64)	38,400 (71.6)	39,100 (75.6)	—	—	—	—	—	—	—
12	80,050 (59.8)	38,400 (68.7)	39,100 (73.4)	39,800 (76.4)	33,650 (78.7)	—	—	—	—	—
15	64,050 (53.1)	38,400 (64.4)	39,100 (70.1)	39,800 (73.5)	33,650 (76.4)	22,250 (78.3)	—	—	—	—
20	46,500 (40.3)	38,400 (56.7)	39,100 (64.4)	39,800 (68.8)	33,650 (72.5)	22,250 (75)	17,450 (77.1)	14,400 (78.6)	—	—
25	30,500 (21.8)	36,800 (47.5)	37,400 (58)	36,650 (63.9)	29,650 (68.4)	22,250 (71.5)	17,450 (74.2)	14,400 (76.1)	12,600 (77.8)	9350 (78.9)
30	—	29,250 (37.3)	29,850 (51.3)	30,200 (58.6)	26,650 (64.2)	20,000 (68)	17,450 (71.2)	14,400 (73.5)	12,600 (75.6)	9350 (76.9)
35	—	21,500 (23.6)	24,350 (43.9)	24,650 (53.1)	24,150 (59.8)	18,100 (64.3)	15,950 (68)	14,400 (70.8)	12,600 (73.2)	9350 (74.8)
40	—	—	20,200 (35.2)	20,550 (47)	20,800 (55.1)	16,650 (60.5)	14,750 (64.7)	13,350 (68)	11,750 (70.8)	9350 (72.7)
45	—	—	15,800 (24)	17,350 (40.3)	17,600 (50)	15,400 (56.5)	13,650 (61.5)	12,250 (65)	11,000 (68.2)	9350 (70.6)
50	—	—	—	14,750 (32.4)	14,950 (44.6)	14,200 (52.3)	12,500 (58)	11,450 (62)	10,350 (65.8)	9350 (68.4)
55	—	—	—	*11,400 (22.2)	12,600 (38.6)	12,750 (47.8)	11,650 (54.4)	10,650 (59.2)	9700 (63.2)	8500 (65.9)
60	—	—	—	—	10,750 (32.4)	10,850 (43.3)	10,900 (50.8)	10,000 (56)	9100 (60.4)	7600 (63.3)
65	—	—	—	—	9210 (23.9)	9380 (37.9)	9510 (46.6)	9400 (52.4)	8550 (57.5)	6750 (60.6)
70	—	—	—	—	*4200 (9.2)	8090 (31.8)	8220 (42.1)	8320 (48.7)	8100 (54.3)	6050 (57.9)
75	—	—	—	—	—	6990 (24.3)	7120 (37.2)	7220 (44.7)	7260 (51)	5450 (55)
80	—	—	—	—	—	*4000 (12.8)	6190 (31.6)	6290 (40.5)	6330 (47.5)	4900 (52.1)
85	—	—	—	—	—	—	5370 (24.8)	5480 (35.8)	5520 (43.8)	4400 (49)
90	—	—	—	—	—	—	*3500 (15.3)	4770 (30.4)	4810 (39.8)	3900 (45.7)
95	—	—	—	—	—	—	—	4140 (24)	4180 (35.4)	3450 (42.2)
100	—	—	—	—	—	—	—	*2500 (14.9)	3630 (30.5)	3050 (38.4)
105	—	—	—	—	—	—	—	—	3130 (24.6)	2750 (34.2)
110	—	—	—	—	—	—	—	—	*2100 (16.8)	2400 (29.5)
115	—	—	—	—	—	—	—	—	—	1650 (23.7)
120	—	—	—	—	—	—	—	—	—	850 (15.8)
Minimum boom angle (°) for indicated length (no load)							0	5	8	10
Maximum boom length (ft) at 0° (no load)							97			

NOTE: () Boom angles are in degrees.
 *Loads are structurally limited.
 #RCL operating code. Refer to RCL manual for operating instructions.

Boom Angle	Lifting Capacities at Zero Degree Boom Angle									
	Main Boom Length in Feet									
	31.7	43-A	54-B	64-C	75-D	86-E				
0°	11,750 (27.6)	6800 (38.8)	4250 (49.8)	3200 (59.8)	1750 (70.8)	750 (81.8)	—	—	—	—

NOTE: () Reference radii in feet. 80095953

THIS CHART IS ONLY A GUIDE AND SHOULD NOT BE USED TO OPERATE THE CRANE.
 The individual crane's load chart, operating instructions and other instructional plates must be read and understood prior to operating the crane.

Load charts



Radius in feet	**26 ft Length		45 ft Length	
	#0005	#0007	#0009	#0011
	0° OFFSET	30° OFFSET	0° OFFSET	30° OFFSET
35	5200 (76.9)	—	—	—
40	5200 (75.3)	—	3700 (77.3)	—
45	5200 (73.6)	—	3700 (75.8)	—
50	5200 (71.9)	4800 (77.4)	3700 (74.4)	—
55	5200 (70.1)	4800 (75.6)	3700 (72.9)	—
60	5200 (68.4)	4800 (73.7)	3700 (71.4)	—
65	5200 (66.7)	4800 (71.7)	3700 (69.9)	2500 (77)
70	4850 (64.7)	4650 (69.7)	3700 (68.4)	2500 (75.2)
75	4500 (62.6)	4400 (67.5)	3700 (66.9)	2500 (73.5)
80	4250 (60.5)	4150 (65.2)	3700 (65.4)	2500 (71.7)
85	3950 (58.3)	4000 (62.9)	3700 (63.8)	2500 (69.8)
90	3790 (56.1)	3800 (60.5)	3550 (61.9)	2500 (67.9)
95	3200 (53.8)	3650 (58.1)	3250 (59.9)	2500 (65.9)
100	2690 (51.2)	3130 (55.4)	3000 (57.8)	2500 (63.9)
105	2230 (48.4)	2620 (52.5)	2700 (55.6)	2450 (61.7)
110	1810 (45.5)	2160 (49.5)	2470 (53.5)	2400 (59.5)
115	1440 (42.5)	1740 (46.3)	2090 (51.2)	2350 (57.1)
120	1100 (39.3)	1360 (42.7)	1750 (48.7)	2300 (54.7)
125	800 (35.8)	1010 (38.9)	1440 (46)	1940 (52.1)
130	520 (32.1)	680 (34.8)	1150 (43.3)	1590 (49.1)
135	—	—	890 (40.4)	1280 (45.9)
140	—	—	650 (37.2)	980 (42.3)
145	—	—	—	700 (38.2)
Min. boom angle for indicated length (no load)	31°	33°	36°	36°
Max. boom length at 0° boom angle (no load)	64 ft		64 ft	

NOTE: () Boom angles are in degrees. 80095954
 #RCL operating code. Refer to RCL manual for instructions.
 *Loads are structurally limited.
 **26 ft. capacities are applicable to both 26' fixed and 26' tele extension.

Boom extension capacity notes:

- 26 ft and 45 ft extension lengths may be used for single line lifting service.
- Radii listed are for a fully extended boom with the boom extension erected. For main boom lengths less than fully extended, the rated loads are determined by boom angle. Use only the column which corresponds to the boom extension length and offset for which the machine is configured. For boom angles not shown, use the rating of the next lower boom angle.
Warning: Operation of this machine with heavier loads than the capacities listed is strictly prohibited. Machine tipping with boom extension occurs rapidly and without advance warning.
- Boom angle is the angle above or below horizontal of the longitudinal axis of the boom base section after lifting rated load.
- Capacities listed are with outriggers properly extended and vertical jacks set only.

THIS CHART IS ONLY A GUIDE AND SHOULD NOT BE USED TO OPERATE THE CRANE.
 The individual crane's load chart, operating instructions and other instructional plates must be read and understood prior to operating the crane.

Load charts



Radius in feet	**26 ft Length		45 ft Length	
	#0006	#0008	#0010	#0012
	0° OFFSET	30° OFFSET	0° OFFSET	30° OFFSET
35	5200 (76.9)	—	—	—
40	5200 (75.3)	—	3700 (77.3)	—
45	5200 (73.6)	—	3700 (75.8)	—
50	5200 (71.9)	4800 (77.4)	3700 (74.4)	—
55	5200 (70.1)	4800 (75.6)	3700 (72.9)	—
60	5200 (68.4)	4800 (73.7)	3700 (71.4)	—
65	5200 (66.7)	4800 (71.7)	3700 (69.9)	2500 (77)
70	4850 (64.7)	4650 (69.7)	3700 (68.4)	2500 (75.2)
75	4500 (62.6)	4400 (67.5)	3700 (66.9)	2500 (73.5)
80	4250 (60.5)	4150 (65.2)	3700 (65.4)	2500 (71.7)
85	3950 (58.3)	4000 (62.9)	3700 (63.8)	2500 (69.8)
90	3800 (56.1)	3800 (60.5)	3550 (61.9)	2500 (67.9)
95	3650 (53.8)	3650 (58.1)	3250 (59.9)	2500 (65.9)
100	3150 (51.2)	3350 (55.4)	3000 (57.8)	2500 (63.9)
105	2600 (48.4)	2900 (52.5)	2700 (55.6)	2450 (61.7)
110	2100 (45.5)	2550 (49.5)	2500 (53.5)	2400 (59.5)
115	1700 (42.5)	2150 (46.3)	2300 (51.2)	2350 (57.1)
120	1350 (39.3)	1650 (42.7)	2050 (48.7)	2300 (54.7)
125	950 (35.8)	1200 (38.9)	1750 (46)	2250 (52.1)
130	650 (32.1)	850 (34.8)	1500 (43.3)	2000 (49.1)
135	—	450 (30)	1200 (40.4)	1750 (45.9)
140	—	—	900 (37.2)	1350 (42.3)
145	—	—	650 (33.9)	900 (38.2)
150	—	—	—	600 (33.9)
Min. boom angle for indicated length (no load)	31°	30°	30°	31°
Max. boom length at 0° boom angle (no load)	64 ft		64 ft	

NOTE: () Boom angles are in degrees. 80095955
 #RCL operating code. Refer to RCL manual for instructions.
 *Loads are structurally limited.
 **26 ft. capacities are applicable to both 26' fixed and 26' tele extension.

Boom extension capacity notes:

- 26 ft and 45 ft extension lengths may be used for single line lifting service.
- Radii listed are for a fully extended boom with the boom extension erected. For main boom lengths less than fully extended, the rated loads are determined by boom angle. Use only the column which corresponds to the boom extension length and offset for which the machine is configured. For boom angles not shown, use the rating of the next lower boom angle.
Warning: Operation of this machine with heavier loads than the capacities listed is strictly prohibited. Machine tipping with boom extension occurs rapidly and without advance warning.
- Boom angle is the angle above or below horizontal of the longitudinal axis of the boom base section after lifting rated load.
- Capacities listed are with outriggers properly extended and vertical jacks set only.

THIS CHART IS ONLY A GUIDE AND SHOULD NOT BE USED TO OPERATE THE CRANE.

The individual crane's load chart, operating instructions and other instructional plates must be read and understood prior to operating the crane.

National Crane NTC55

15

Load charts



9,7 m – 39,0 m
(31.7 ft – 128 ft)



2494 kg
(5500 lb)



75%



360°



Pounds

Radius in feet	#0201									
	Main Boom Length in Feet									
	31.7	43-A	54-B	64-C	75-D	86-E	97-F	107-G	118-H	128
8	102,500 (68.1)	—	—	—	—	—	—	—	—	—
10	90,200 (64)	39,200 (71.6)	39,700 (75.6)	—	—	—	—	—	—	—
12	80,150 (59.8)	39,200 (68.7)	39,700 (73.4)	40,300 (76.4)	34,100 (78.7)	—	—	—	—	—
15	65,200 (53.1)	39,200 (64.4)	39,700 (70.1)	40,300 (73.5)	34,100 (76.4)	22,650 (78.3)	—	—	—	—
20	47,650 (40.3)	39,200 (56.7)	39,700 (64.4)	40,300 (68.8)	34,100 (72.5)	22,650 (75)	17,800 (77.1)	14,700 (78.6)	—	—
25	31,650 (21.8)	33,150 (47.5)	33,600 (58)	33,750 (63.9)	30,100 (68.4)	22,650 (71.5)	17,800 (74.2)	14,700 (76.1)	12,900 (77.8)	9600 (78.9)
30	—	23,300 (37.3)	23,700 (51.3)	23,950 (58.6)	24,100 (64.2)	20,400 (68)	17,800 (71.2)	14,700 (73.5)	12,900 (75.6)	9600 (76.9)
35	—	17,350 (23.6)	17,800 (43.9)	18,050 (53.1)	18,200 (59.8)	18,300 (64.3)	16,300 (68)	14,700 (70.8)	12,900 (73.2)	9600 (74.8)
40	—	—	13,800 (35.2)	14,050 (47)	14,200 (55.1)	14,300 (60.5)	14,350 (64.7)	13,650 (68)	12,050 (70.8)	9600 (72.7)
45	—	—	10,950 (24)	11,200 (40.3)	11,350 (50)	11,450 (56.5)	11,500 (61.5)	11,550 (65)	11,300 (68.2)	9600 (70.6)
50	—	—	—	9090 (32.4)	9260 (44.6)	9380 (52.3)	9450 (58)	9500 (62)	9540 (65.8)	9570 (68.4)
55	—	—	—	7390 (22.2)	7580 (38.6)	7690 (47.8)	7770 (54.4)	7820 (59.2)	7860 (63.2)	7890 (65.9)
60	—	—	—	—	6230 (32.4)	6350 (43.3)	6420 (50.8)	6470 (56)	6510 (60.4)	6540 (63.3)
65	—	—	—	—	5120 (23.9)	5240 (37.9)	5320 (46.6)	5370 (52.4)	5410 (57.5)	5440 (60.6)
70	—	—	—	—	4170 (9.2)	4320 (31.8)	4400 (42.1)	4450 (48.7)	4490 (54.3)	4520 (57.9)
75	—	—	—	—	—	3530 (24.3)	3620 (37.2)	3670 (44.7)	3710 (51)	3740 (55)
80	—	—	—	—	—	2850 (12.8)	2950 (31.6)	3000 (40.5)	3040 (47.5)	3070 (52.1)
85	—	—	—	—	—	—	2370 (24.8)	2420 (35.8)	2460 (43.8)	2490 (49)
90	—	—	—	—	—	—	1850 (15.3)	1920 (30.4)	1960 (39.8)	1990 (45.7)
95	—	—	—	—	—	—	—	1470 (24)	1510 (35.4)	1540 (42.2)
100	—	—	—	—	—	—	—	1060 (14.9)	1110 (30.5)	1140 (38.4)
105	—	—	—	—	—	—	—	—	760 (24.6)	790 (34.2)
Minimum boom angle (°) for indicated length (no load)							6	13	23	32
Maximum boom length (ft) at 0° (no load)							86			

NOTE: () Boom angles are in degrees.
#RCL operating code. Refer to RCL manual for operating instructions.

Boom Angle	Lifting Capacities at Zero Degree Boom Angle									
	Main Boom Length in Feet									
	31.7	43-A	54-B	64-C	75-D	86-E				
0°	12,900 (27.6)	7600 (38.8)	4850 (49.8)	3700 (59.8)	2200 (70.8)	1150 (81.8)	—	—	—	—

NOTE: () Reference radii in feet.

80094306A

THIS CHART IS ONLY A GUIDE AND SHOULD NOT BE USED TO OPERATE THE CRANE.
The individual crane's load chart, operating instructions and other instructional plates must be read and understood prior to operating the crane.

Load charts

9,7 m – 39,0 m (31.7 ft – 128 ft)
 Stowed
 2494 kg (5500 lb)
 75%
 360°

Pounds

Radius in feet	#0202									
	Main Boom Length in Feet									
	31.7	43-A	54-B	64-C	75-D	86-E	97-F	107-G	118-H	128
8	101,000 (68.1)	—	—	—	—	—	—	—	—	—
10	89,050 (64)	38,400 (71.6)	39,100 (75.6)	—	—	—	—	—	—	—
12	79,000 (59.8)	38,400 (68.7)	39,100 (73.4)	39,800 (76.4)	33,650 (78.7)	—	—	—	—	—
15	64,050 (53.1)	38,400 (64.4)	39,100 (70.1)	39,800 (73.5)	33,650 (76.4)	22,250 (78.3)	—	—	—	—
20	46,500 (40.3)	38,400 (56.7)	39,100 (64.4)	39,800 (68.8)	33,650 (72.5)	22,250 (75)	17,450 (77.1)	14,400 (78.6)	—	—
25	30,500 (21.8)	32,350 (47.5)	33,000 (58)	33,250 (63.9)	29,650 (68.4)	22,250 (71.5)	17,450 (74.2)	14,400 (76.1)	12,600 (77.8)	9350 (78.9)
30	—	22,500 (37.3)	23,100 (51.3)	23,450 (58.6)	23,650 (64.2)	20,000 (68)	17,450 (71.2)	14,400 (73.5)	12,600 (75.6)	9350 (76.9)
35	—	16,550 (23.6)	17,200 (43.9)	17,550 (53.1)	17,750 (59.8)	17,900 (64.3)	15,950 (68)	14,400 (70.8)	12,600 (73.2)	9350 (74.8)
40	—	—	13,200 (35.2)	13,550 (47)	13,750 (55.1)	13,900 (60.5)	14,000 (64.7)	13,350 (68)	11,750 (70.8)	9350 (72.7)
45	—	—	10,350 (24)	10,700 (40.3)	10,900 (50)	11,050 (56.5)	11,150 (61.5)	11,250 (65)	11,000 (68.2)	9350 (70.6)
50	—	—	—	8590 (32.4)	8810 (44.6)	8980 (52.3)	9100 (58)	9200 (62)	9240 (65.8)	9320 (68.4)
55	—	—	—	6890 (22.2)	7130 (38.6)	7290 (47.8)	7420 (54.4)	7520 (59.2)	7560 (63.2)	7640 (65.9)
60	—	—	—	—	5780 (32.4)	5950 (43.3)	6070 (50.8)	6170 (56)	6210 (60.4)	6290 (63.3)
65	—	—	—	—	4670 (23.9)	4840 (37.9)	4970 (46.6)	5070 (52.4)	5110 (57.5)	5190 (60.6)
70	—	—	—	—	3720 (9.2)	3920 (31.8)	4050 (42.1)	4150 (48.7)	4190 (54.3)	4270 (57.9)
75	—	—	—	—	—	3130 (24.3)	3270 (37.2)	3370 (44.7)	3410 (51)	3490 (55)
80	—	—	—	—	—	2450 (12.8)	2600 (31.6)	2700 (40.5)	2740 (47.5)	2820 (52.1)
85	—	—	—	—	—	—	2020 (24.8)	2120 (35.8)	2160 (43.8)	2240 (49)
90	—	—	—	—	—	—	1500 (15.3)	1620 (30.4)	1660 (39.8)	1740 (45.7)
95	—	—	—	—	—	—	—	1170 (24)	1210 (35.4)	1290 (42.2)
100	—	—	—	—	—	—	—	760 (14.9)	810 (30.5)	890 (38.4)
105	—	—	—	—	—	—	—	—	—	540 (34.2)
Minimum boom angle (°) for indicated length (no load)							6	13	28	32
Maximum boom length (ft) at 0° (no load)							86			

NOTE: () Boom angles are in degrees.
#RCL operating code. Refer to RCL manual for operating instructions.

Boom Angle	Lifting Capacities at Zero Degree Boom Angle									
	Main Boom Length in Feet									
	31.7	43-A	54-B	64-C	75-D	86-E				
0°	11,750 (27.6)	6800 (38.8)	4250 (49.8)	3200 (59.8)	1750 (70.8)	750 (81.8)	—	—	—	—

NOTE: () Reference radii in feet. 80094307A

THIS CHART IS ONLY A GUIDE AND SHOULD NOT BE USED TO OPERATE THE CRANE.
The individual crane's load chart, operating instructions and other instructional plates must be read and understood prior to operating the crane.

Load charts



Radius in feet	**26 ft Length		45 ft Length	
	#0205	#0207	#0209	#0211
	0° OFFSET	30° OFFSET	0° OFFSET	30° OFFSET
35	5200 (76.9)	—	—	—
40	5200 (75.3)	—	3700 (77.3)	—
45	5200 (73.6)	—	3700 (75.8)	—
50	5200 (71.9)	4800 (77.4)	3700 (74.4)	—
55	5200 (70.1)	4800 (75.6)	3700 (72.9)	—
60	5200 (68.4)	4800 (73.7)	3700 (71.4)	—
65	5000 (66.7)	4800 (71.7)	3700 (69.9)	2500 (77)
70	4080 (64.7)	4650 (69.7)	3700 (68.4)	2500 (75.2)
75	3290 (62.6)	4070 (67.5)	3700 (66.9)	2500 (73.5)
80	2620 (60.5)	3320 (65.2)	3320 (65.4)	2500 (71.7)
85	2040 (58.3)	2660 (62.9)	2730 (63.8)	2500 (69.8)
90	1530 (56.1)	2090 (60.5)	2220 (61.9)	2500 (67.9)
95	1090 (53.8)	1580 (58.1)	1760 (59.9)	2500 (65.9)
100	690 (51.2)	1130 (55.4)	1360 (57.8)	2190 (63.9)
105	—	730 (52.5)	1000 (55.6)	1750 (61.7)
110	—	—	670 (53.5)	1360 (59.5)
115	—	—	—	1000 (57.1)
120	—	—	—	670 (54.7)
Min. boom angle for indicated length (no load)	50°	51°	52°	53°
Max. boom length at 0° boom angle (no load)	64 ft		64 ft	



NOTE: () Boom angles are in degrees. 80094312A
 #RCL operating code. Refer to RCL manual for instructions.
 *Loads are structurally limited.
 **26 ft. capacities are applicable to both 26' fixed and 26' tele extension.



Boom extension capacity notes:

- 26 ft and 45 ft extension lengths may be used for single line lifting service.
- Radii listed are for a fully extended boom with the boom extension erected. For main boom lengths less than fully extended, the rated loads are determined by boom angle. Use only the column which corresponds to the boom extension length and offset for which the machine is configured. For boom angles not shown, use the rating of the next lower boom angle.
Warning: Operation of this machine with heavier loads than the capacities listed is strictly prohibited. Machine tipping with boom extension occurs rapidly and without advance warning.
- Boom angle is the angle above or below horizontal of the longitudinal axis of the boom base section after lifting rated load.
- Capacities listed are with outriggers properly extended and vertical jacks set only.

THIS CHART IS ONLY A GUIDE AND SHOULD NOT BE USED TO OPERATE THE CRANE.
 The individual crane's load chart, operating instructions and other instructional plates must be read and understood prior to operating the crane.

Load charts

 9,7 m – 39,0 m
(31.7 ft – 128 ft)
  1928 kg
(4250 lb)
  100%
  360°

 Pounds

Radius in feet	#4001									
	Main Boom Length in Feet									
	31.7	43-A	54-B	64-C	75-D	86-E	97-F	107-G	118-H	128
8	109,500 (68.1)	—	—	—	—	—	—	—	—	—
10	92,300 (64)	39,200 (71.6)	39,700 (75.6)	—	—	—	—	—	—	—
12	81,150 (59.8)	39,200 (68.7)	39,700 (73.4)	40,300 (76.4)	34,100 (78.7)	—	—	—	—	—
15	64,350 (53.1)	39,200 (64.4)	39,700 (70.1)	40,300 (73.5)	34,100 (76.4)	22,650 (78.3)	—	—	—	—
20	47,050 (40.3)	39,200 (56.7)	39,700 (64.4)	40,300 (68.8)	34,100 (72.5)	22,650 (75)	17,800 (77.1)	14,700 (78.6)	—	—
25	31,650 (21.8)	37,100 (47.5)	37,500 (58)	37,150 (63.9)	30,100 (68.4)	22,650 (71.5)	17,800 (74.2)	14,700 (76.1)	12,900 (77.8)	9600 (78.9)
30	—	29,500 (37.3)	29,900 (51.3)	30,150 (58.6)	27,100 (64.2)	20,400 (68)	17,800 (71.2)	14,700 (73.5)	12,900 (75.6)	9600 (76.9)
35	—	22,300 (23.6)	24,450 (43.9)	24,700 (53.1)	24,600 (59.8)	18,500 (64.3)	16,300 (68)	14,700 (70.8)	12,900 (73.2)	9600 (74.8)
40	—	—	19,550 (35.2)	19,800 (47)	20,000 (55.1)	17,050 (60.5)	15,100 (64.7)	13,650 (68)	12,050 (70.8)	9600 (72.7)
45	—	—	15,700 (24)	15,950 (40.3)	16,100 (50)	15,800 (56.5)	14,000 (61.5)	12,550 (65)	11,300 (68.2)	9600 (70.6)
50	—	—	—	13,050 (32.4)	13,250 (44.6)	13,350 (52.3)	12,850 (58)	11,750 (62)	10,650 (65.8)	9600 (68.4)
55	—	—	—	10,900 (22.2)	11,100 (38.6)	11,200 (47.8)	11,200 (54.4)	10,950 (59.2)	10,000 (63.2)	8750 (65.9)
60	—	—	—	—	9350 (32.4)	9470 (43.3)	9550 (50.8)	9600 (56)	9400 (60.4)	7850 (63.3)
65	—	—	—	—	7920 (23.9)	8050 (37.9)	8130 (46.6)	8170 (52.4)	8210 (57.5)	7000 (60.6)
70	—	—	—	—	*4650 (9.2)	6860 (31.8)	6950 (42.1)	7000 (48.7)	7030 (54.3)	6300 (57.9)
75	—	—	—	—	—	5870 (24.3)	5950 (37.2)	6000 (44.7)	6040 (51)	5700 (55)
80	—	—	—	—	—	*4400 (12.8)	5110 (31.6)	5160 (40.5)	5200 (47.5)	5150 (52.1)
85	—	—	—	—	—	—	4370 (24.8)	4430 (35.8)	4470 (43.8)	4500 (49)
90	—	—	—	—	—	—	3730 (15.3)	3790 (30.4)	3830 (39.8)	3860 (45.7)
95	—	—	—	—	—	—	—	3230 (24)	3270 (35.4)	3300 (42.2)
100	—	—	—	—	—	—	—	2730 (14.9)	2770 (30.5)	2810 (38.4)
105	—	—	—	—	—	—	—	—	2330 (24.6)	2360 (34.2)
110	—	—	—	—	—	—	—	—	1930 (16.8)	1970 (29.5)
115	—	—	—	—	—	—	—	—	—	1610 (23.7)
120	—	—	—	—	—	—	—	—	—	*1100 (15.8)
Minimum boom angle (°) for indicated length (no load)							0	5	8	10
Maximum boom length (ft) at 0° (no load)							97			

NOTE: () Boom angles are in degrees.
 *Loads are structurally limited.
 #RCL operating code. Refer to RCL manual for operating instructions.

Boom Angle	Lifting Capacities at Zero Degree Boom Angle									
	Main Boom Length in Feet									
	31.7	43-A	54-B	64-C	75-D	86-E				
0°	12,900 (27.6)	7600 (38.8)	4850 (49.8)	3700 (59.8)	2200 (70.8)	1150 (81.8)	—	—	—	—

NOTE: () Reference radii in feet. 80094313A

THIS CHART IS ONLY A GUIDE AND SHOULD NOT BE USED TO OPERATE THE CRANE.
 The individual crane's load chart, operating instructions and other instructional plates must be read and understood prior to operating the crane.

Load charts

9,7 m – 39,0 m
(31.7 ft – 128 ft)

Stowed

1928 kg
(4250 lb)

100%

360°



Pounds

Radius in feet	#4002									
	Main Boom Length in Feet									
	31.7	43-A	54-B	64-C	75-D	86-E	97-F	107-G	118-H	128
8	108,000 (68.1)	—	—	—	—	—	—	—	—	—
10	91,150 (64)	38,400 (71.6)	39,100 (75.6)	—	—	—	—	—	—	—
12	80,000 (59.8)	38,400 (68.7)	39,100 (73.4)	39,800 (76.4)	33,650 (78.7)	—	—	—	—	—
15	63,200 (53.1)	38,400 (64.4)	39,100 (70.1)	39,800 (73.5)	33,650 (76.4)	22,250 (78.3)	—	—	—	—
20	45,900 (40.3)	38,400 (56.7)	39,100 (64.4)	39,800 (68.8)	33,650 (72.5)	22,250 (75)	17,450 (77.1)	14,400 (78.6)	—	—
25	30,500 (21.8)	36,300 (47.5)	36,900 (58)	36,650 (63.9)	29,650 (68.4)	22,250 (71.5)	17,450 (74.2)	14,400 (76.1)	12,600 (77.8)	9350 (78.9)
30	—	28,700 (37.3)	29,300 (51.3)	29,650 (58.6)	26,650 (64.2)	20,000 (68)	17,450 (71.2)	14,400 (73.5)	12,600 (75.6)	9350 (76.9)
35	—	21,500 (23.6)	23,850 (43.9)	24,200 (53.1)	24,150 (59.8)	18,100 (64.3)	15,950 (68)	14,400 (70.8)	12,600 (73.2)	9350 (74.8)
40	—	—	18,950 (35.2)	19,300 (47)	19,550 (55.1)	16,650 (60.5)	14,750 (64.7)	13,350 (68)	11,750 (70.8)	9350 (72.7)
45	—	—	15,100 (24)	15,450 (40.3)	15,650 (50)	15,400 (56.5)	13,650 (61.5)	12,250 (65)	11,000 (68.2)	9350 (70.6)
50	—	—	—	12,550 (32.4)	12,800 (44.6)	12,950 (52.3)	12,500 (58)	11,450 (62)	10,350 (65.8)	9350 (68.4)
55	—	—	—	10,400 (22.2)	10,650 (38.6)	10,800 (47.8)	10,850 (54.4)	10,650 (59.2)	9700 (63.2)	8500 (65.9)
60	—	—	—	—	8900 (32.4)	9070 (43.3)	9200 (50.8)	9300 (56)	9100 (60.4)	7600 (63.3)
65	—	—	—	—	7470 (23.9)	7650 (37.9)	7780 (46.6)	7870 (52.4)	7910 (57.5)	6750 (60.6)
70	—	—	—	—	*4200 (9.2)	6460 (31.8)	6600 (42.1)	6700 (48.7)	6730 (54.3)	6050 (57.9)
75	—	—	—	—	—	5470 (24.3)	5600 (37.2)	5700 (44.7)	5740 (51)	5450 (55)
80	—	—	—	—	—	*4000 (12.8)	4760 (31.6)	4860 (40.5)	4900 (47.5)	4900 (52.1)
85	—	—	—	—	—	—	4020 (24.8)	4130 (35.8)	4170 (43.8)	4250 (49)
90	—	—	—	—	—	—	3380 (15.3)	3490 (30.4)	3530 (39.8)	3610 (45.7)
95	—	—	—	—	—	—	—	2930 (24)	2970 (35.4)	3050 (42.2)
100	—	—	—	—	—	—	—	2430 (14.9)	2470 (30.5)	2560 (38.4)
105	—	—	—	—	—	—	—	—	2030 (24.6)	2110 (34.2)
110	—	—	—	—	—	—	—	—	1630 (16.8)	1720 (29.5)
115	—	—	—	—	—	—	—	—	—	1360 (23.7)
120	—	—	—	—	—	—	—	—	—	*850 (15.8)
Minimum boom angle (°) for indicated length (no load)							0	5	8	10
Maximum boom length (ft) at 0° (no load)							97			





NOTE: () Boom angles are in degrees.
*Loads are structurally limited.
#RCL operating code. Refer to RCL manual for operating instructions.



Boom Angle	Lifting Capacities at Zero Degree Boom Angle									
	Main Boom Length in Feet									
	31.7	43-A	54-B	64-C	75-D	86-E				
0°	11,750 (27.6)	6800 (38.8)	4250 (49.8)	3200 (59.8)	1750 (70.8)	750 (81.8)	—	—	—	—

NOTE: () Reference radii in feet. 80094314A

THIS CHART IS ONLY A GUIDE AND SHOULD NOT BE USED TO OPERATE THE CRANE.
The individual crane's load chart, operating instructions and other instructional plates must be read and understood prior to operating the crane.

Load charts

 9,7 m – 39,0 m
(31.7 ft – 128 ft)
  1928 kg
(4250 lb)
  100%
  Over Rear

 Pounds

Radius in feet	#4003									
	Main Boom Length in Feet									
	31.7	43-A	54-B	64-C	75-D	86-E	97-F	107-G	118-H	128
8	109,500 (68.1)	—	—	—	—	—	—	—	—	—
10	92,300 (64)	39,200 (71.6)	39,700 (75.6)	—	—	—	—	—	—	—
12	81,150 (59.8)	39,200 (68.7)	39,700 (73.4)	40,300 (76.4)	34,100 (78.7)	—	—	—	—	—
15	64,350 (53.1)	39,200 (64.4)	39,700 (70.1)	40,300 (73.5)	34,100 (76.4)	22,650 (78.3)	—	—	—	—
20	47,050 (40.3)	39,200 (56.7)	39,700 (64.4)	40,300 (68.8)	34,100 (72.5)	22,650 (75)	17,800 (77.1)	14,700 (78.6)	—	—
25	31,650 (21.8)	37,100 (47.5)	37,500 (58)	37,150 (63.9)	30,100 (68.4)	22,650 (71.5)	17,800 (74.2)	14,700 (76.1)	12,900 (77.8)	9600 (78.9)
30	—	29,500 (37.3)	29,900 (51.3)	30,150 (58.6)	27,100 (64.2)	20,400 (68)	17,800 (71.2)	14,700 (73.5)	12,900 (75.6)	9600 (76.9)
35	—	22,300 (23.6)	24,450 (43.9)	24,700 (53.1)	24,600 (59.8)	18,500 (64.3)	16,300 (68)	14,700 (70.8)	12,900 (73.2)	9600 (74.8)
40	—	—	20,400 (35.2)	20,650 (47)	20,850 (55.1)	17,050 (60.5)	15,100 (64.7)	13,650 (68)	12,050 (70.8)	9600 (72.7)
45	—	—	16,400 (24)	17,500 (40.3)	17,700 (50)	15,800 (56.5)	14,000 (61.5)	12,550 (65)	11,300 (68.2)	9600 (70.6)
50	—	—	—	14,700 (32.4)	14,850 (44.6)	14,600 (52.3)	12,850 (58)	11,750 (62)	10,650 (65.8)	9600 (68.4)
55	—	—	—	*11,900 (22.2)	12,550 (38.6)	12,600 (47.8)	12,000 (54.4)	10,950 (59.2)	10,000 (63.2)	8750 (65.9)
60	—	—	—	—	10,750 (32.4)	10,850 (43.3)	10,950 (50.8)	10,300 (56)	9400 (60.4)	7850 (63.3)
65	—	—	—	—	9240 (23.9)	9360 (37.9)	9440 (46.6)	9490 (52.4)	8850 (57.5)	7000 (60.6)
70	—	—	—	—	*4650 (9.2)	8100 (31.8)	8180 (42.1)	8230 (48.7)	8270 (54.3)	6300 (57.9)
75	—	—	—	—	—	7030 (24.3)	7120 (37.2)	7170 (44.7)	7200 (51)	5700 (55)
80	—	—	—	—	—	*4400 (12.8)	6210 (31.6)	6260 (40.5)	6290 (47.5)	5150 (52.1)
85	—	—	—	—	—	—	5410 (24.8)	5470 (35.8)	5510 (43.8)	4650 (49)
90	—	—	—	—	—	—	*3850 (15.3)	4780 (30.4)	4820 (39.8)	4150 (45.7)
95	—	—	—	—	—	—	—	4170 (24)	4210 (35.4)	3700 (42.2)
100	—	—	—	—	—	—	—	*2800 (14.9)	3670 (30.5)	3300 (38.4)
105	—	—	—	—	—	—	—	—	3190 (24.6)	3000 (34.2)
110	—	—	—	—	—	—	—	—	*2400 (16.8)	2650 (29.5)
115	—	—	—	—	—	—	—	—	—	1900 (23.7)
120	—	—	—	—	—	—	—	—	—	1100 (15.8)
Minimum boom angle (°) for indicated length (no load)							0	5	8	10
Maximum boom length (ft) at 0° (no load)							97			

NOTE: () Boom angles are in degrees.
 *Loads are structurally limited.
 #RCL operating code. Refer to RCL manual for operating instructions.

Boom Angle	Lifting Capacities at Zero Degree Boom Angle									
	Main Boom Length in Feet									
	31.7	43-A	54-B	64-C	75-D	86-E				
0°	12,900 (27.6)	7600 (38.8)	4850 (49.8)	3700 (59.8)	2200 (70.8)	1150 (81.8)	—	—	—	—

NOTE: () Reference radii in feet. 80094317A

THIS CHART IS ONLY A GUIDE AND SHOULD NOT BE USED TO OPERATE THE CRANE.
 The individual crane's load chart, operating instructions and other instructional plates must be read and understood prior to operating the crane.

Load charts

 9,7 m – 39,0 m
(31.7 ft – 128 ft)

 Stowed

 1928 kg
(4250 lb)

 100%

 Over Rear



 Pounds

Radius in feet	#4004									
	Main Boom Length in Feet									
	31.7	43-A	54-B	64-C	75-D	86-E	97-F	107-G	118-H	128
8	108,000 (68.1)	—	—	—	—	—	—	—	—	—
10	91,150 (64)	38,400 (71.6)	39,100 (75.6)	—	—	—	—	—	—	—
12	80,000 (59.8)	38,400 (68.7)	39,100 (73.4)	39,800 (76.4)	33,650 (78.7)	—	—	—	—	—
15	63,200 (53.1)	38,400 (64.4)	39,100 (70.1)	39,800 (73.5)	33,650 (76.4)	22,250 (78.3)	—	—	—	—
20	45,900 (40.3)	38,400 (56.7)	39,100 (64.4)	39,800 (68.8)	33,650 (72.5)	22,250 (75)	17,450 (77.1)	14,400 (78.6)	—	—
25	30,500 (21.8)	36,300 (47.5)	36,900 (58)	36,650 (63.9)	29,650 (68.4)	22,250 (71.5)	17,450 (74.2)	14,400 (76.1)	12,600 (77.8)	9350 (78.9)
30	—	28,700 (37.3)	29,300 (51.3)	29,650 (58.6)	26,650 (64.2)	20,000 (68)	17,450 (71.2)	14,400 (73.5)	12,600 (75.6)	9350 (76.9)
35	—	21,500 (23.6)	23,850 (43.9)	24,200 (53.1)	24,150 (59.8)	18,100 (64.3)	15,950 (68)	14,400 (70.8)	12,600 (73.2)	9350 (74.8)
40	—	—	19,800 (35.2)	20,150 (47)	20,400 (55.1)	16,650 (60.5)	14,750 (64.7)	13,350 (68)	11,750 (70.8)	9350 (72.7)
45	—	—	15,800 (24)	17,000 (40.3)	17,250 (50)	15,400 (56.5)	13,650 (61.5)	12,250 (65)	11,000 (68.2)	9350 (70.6)
50	—	—	—	14,200 (32.4)	14,400 (44.6)	14,200 (52.3)	12,500 (58)	11,450 (62)	10,350 (65.8)	9350 (68.4)
55	—	—	—	11,400 (22.2)	12,100 (38.6)	12,200 (47.8)	11,650 (54.4)	10,650 (59.2)	9700 (63.2)	8500 (65.9)
60	—	—	—	—	10,300 (32.4)	10,450 (43.3)	10,600 (50.8)	10,000 (56)	9100 (60.4)	7600 (63.3)
65	—	—	—	—	8790 (23.9)	8960 (37.9)	9090 (46.6)	9190 (52.4)	8550 (57.5)	6750 (60.6)
70	—	—	—	—	*4200 (9.2)	7700 (31.8)	7830 (42.1)	7930 (48.7)	7970 (54.3)	6050 (57.9)
75	—	—	—	—	—	6630 (24.3)	6770 (37.2)	6870 (44.7)	6900 (51)	5450 (55)
80	—	—	—	—	—	*4000 (12.8)	5860 (31.6)	5960 (40.5)	5990 (47.5)	4900 (52.1)
85	—	—	—	—	—	—	5060 (24.8)	5170 (35.8)	5210 (43.8)	4400 (49)
90	—	—	—	—	—	—	*3500 (15.3)	4480 (30.4)	4520 (39.8)	3900 (45.7)
95	—	—	—	—	—	—	—	3870 (24)	3910 (35.4)	3450 (42.2)
100	—	—	—	—	—	—	—	*2500 (14.9)	3370 (30.5)	3050 (38.4)
105	—	—	—	—	—	—	—	—	2890 (24.6)	2750 (34.2)
110	—	—	—	—	—	—	—	—	*2100 (16.8)	2400 (29.5)
115	—	—	—	—	—	—	—	—	—	1650 (23.7)
120	—	—	—	—	—	—	—	—	—	850 (15.8)
Minimum boom angle (°) for indicated length (no load)							0	5	8	10
Maximum boom length (ft) at 0° (no load)							97			

NOTE: () Boom angles are in degrees.

*Loads are structurally limited.

#RCL operating code. Refer to RCL manual for operating instructions.

Boom Angle	Lifting Capacities at Zero Degree Boom Angle									
	Main Boom Length in Feet									
	31.7	43-A	54-B	64-C	75-D	86-E	97-F	107-G	118-H	128
0°	11,750 (27.6)	6800 (38.8)	4250 (49.8)	3200 (59.8)	1750 (70.8)	750 (81.8)	—	—	—	—

NOTE: () Reference radii in feet.

80094318A

THIS CHART IS ONLY A GUIDE AND SHOULD NOT BE USED TO OPERATE THE CRANE.
The individual crane's load chart, operating instructions and other instructional plates must be read and understood prior to operating the crane.

Load charts



Radius in feet	**26 ft Length		45 ft Length	
	#4005	#4007	#4009	#4011
	0° OFFSET	30° OFFSET	0° OFFSET	30° OFFSET
35	5200 (76.9)	—	—	—
40	5200 (75.3)	—	3700 (77.3)	—
45	5200 (73.6)	—	3700 (75.8)	—
50	5200 (71.9)	4800 (77.4)	3700 (74.4)	—
55	5200 (70.1)	4800 (75.6)	3700 (72.9)	—
60	5200 (68.4)	4800 (73.7)	3700 (71.4)	—
65	5200 (66.7)	4800 (71.7)	3700 (69.9)	2500 (77)
70	4850 (64.7)	4650 (69.7)	3700 (68.4)	2500 (75.2)
75	4500 (62.6)	4400 (67.5)	3700 (66.9)	2500 (73.5)
80	4250 (60.5)	4150 (65.2)	3700 (65.4)	2500 (71.7)
85	3950 (58.3)	4000 (62.9)	3700 (63.8)	2500 (69.8)
90	3470 (56.1)	3800 (60.5)	3550 (61.9)	2500 (67.9)
95	2900 (53.8)	3400 (58.1)	3250 (59.9)	2500 (65.9)
100	2400 (51.2)	2850 (55.4)	3000 (57.8)	2500 (63.9)
105	1960 (48.4)	2350 (52.5)	2620 (55.6)	2450 (61.7)
110	1560 (45.5)	1910 (49.5)	2220 (53.5)	2400 (59.5)
115	1200 (42.5)	1500 (46.3)	1850 (51.2)	2350 (57.1)
120	870 (39.3)	1130 (42.7)	1520 (48.7)	2080 (54.7)
125	580 (35.8)	790 (38.9)	1220 (46)	1720 (52.1)
130	—	470 (34.8)	940 (43.3)	1380 (49.1)
135	—	—	690 (40.4)	1080 (45.9)
140	—	—	460 (37.2)	790 (42.3)
145	—	—	—	520 (38.2)
Min. boom angle for indicated length (no load)	33°	33°	36°	36°
Max. boom length at 0° boom angle (no load)	64 ft		64 ft	

NOTE: () Boom angles are in degrees. 80094319A
 #RCL operating code. Refer to RCL manual for instructions.
 *Loads are structurally limited.
 **26 ft. capacities are applicable to both 26' fixed and 26' tele extension.

Boom extension capacity notes:

- 26 ft and 45 ft extension lengths may be used for single line lifting service.
- Radii listed are for a fully extended boom with the boom extension erected. For main boom lengths less than fully extended, the rated loads are determined by boom angle. Use only the column which corresponds to the boom extension length and offset for which the machine is configured. For boom angles not shown, use the rating of the next lower boom angle.
Warning: Operation of this machine with heavier loads than the capacities listed is strictly prohibited. Machine tipping with boom extension occurs rapidly and without advance warning.
- Boom angle is the angle above or below horizontal of the longitudinal axis of the boom base section after lifting rated load.
- Capacities listed are with outriggers properly extended and vertical jacks set only.

THIS CHART IS ONLY A GUIDE AND SHOULD NOT BE USED TO OPERATE THE CRANE.

The individual crane's load chart, operating instructions and other instructional plates must be read and understood prior to operating the crane.

Load charts

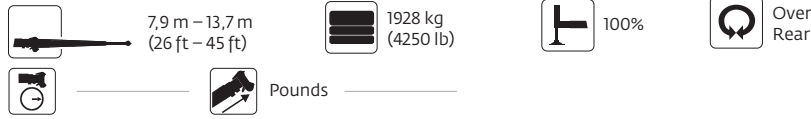

Radius in feet	**26 ft Length		45 ft Length	
	#4006	#4008	#4010	#4012
	0° OFFSET	30° OFFSET	0° OFFSET	30° OFFSET
35	5200 (76.9)	—	—	—
40	5200 (75.3)	—	3700 (77.3)	—
45	5200 (73.6)	—	3700 (75.8)	—
50	5200 (71.9)	4800 (77.4)	3700 (74.4)	—
55	5200 (70.1)	4800 (75.6)	3700 (72.9)	—
60	5200 (68.4)	4800 (73.7)	3700 (71.4)	—
65	5200 (66.7)	4800 (71.7)	3700 (69.9)	2500 (77)
70	4850 (64.7)	4650 (69.7)	3700 (68.4)	2500 (75.2)
75	4500 (62.6)	4400 (67.5)	3700 (66.9)	2500 (73.5)
80	4250 (60.5)	4150 (65.2)	3700 (65.4)	2500 (71.7)
85	3950 (58.3)	4000 (62.9)	3700 (63.8)	2500 (69.8)
90	3800 (56.1)	3800 (60.5)	3550 (61.9)	2500 (67.9)
95	3650 (53.8)	3650 (58.1)	3250 (59.9)	2500 (65.9)
100	3150 (51.2)	3350 (55.4)	3000 (57.8)	2500 (63.9)
105	2600 (48.4)	2900 (52.5)	2700 (55.6)	2450 (61.7)
110	2100 (45.5)	2550 (49.5)	2500 (53.5)	2400 (59.5)
115	1700 (42.5)	2150 (46.3)	2300 (51.2)	2350 (57.1)
120	1350 (39.3)	1650 (42.7)	2050 (48.7)	2300 (54.7)
125	950 (35.8)	1200 (38.9)	1750 (46)	2250 (52.1)
130	650 (32.1)	850 (34.8)	1500 (43.3)	2000 (49.1)
135	—	450 (30)	1200 (40.4)	1720 (45.9)
140	—	—	900 (37.2)	1350 (42.3)
145	—	—	650 (33.9)	900 (38.2)
150	—	—	—	600 (33.9)
Min. boom angle for indicated length (no load)	29°	30°	30°	31°
Max. boom length at 0° boom angle (no load)	64 ft		64 ft	

NOTE: () Boom angles are in degrees. 80094320A
 #RCL operating code. Refer to RCL manual for instructions.
 *Loads are structurally limited.
 **26 ft. capacities are applicable to both 26' fixed and 26' tele extension.

Boom extension capacity notes:

- 26 ft and 45 ft extension lengths may be used for single line lifting service.
- Radii listed are for a fully extended boom with the boom extension erected. For main boom lengths less than fully extended, the rated loads are determined by boom angle. Use only the column which corresponds to the boom extension length and offset for which the machine is configured. For boom angles not shown, use the rating of the next lower boom angle.
Warning: Operation of this machine with heavier loads than the capacities listed is strictly prohibited. Machine tipping with boom extension occurs rapidly and without advance warning.
- Boom angle is the angle above or below horizontal of the longitudinal axis of the boom base section after lifting rated load.
- Capacities listed are with outriggers properly extended and vertical jacks set only.

THIS CHART IS ONLY A GUIDE AND SHOULD NOT BE USED TO OPERATE THE CRANE.
 The individual crane's load chart, operating instructions and other instructional plates must be read and understood prior to operating the crane.

To learn more about this model, call 414-764-9200 or visit giuffre.com today!

Load charts

 9,7 m – 39,0 m
(31.7 ft – 128 ft)
  1928 kg
(4250 lb)
  75%
  360°

 Pounds

Radius in feet	#4201									
	Main Boom Length in Feet									
	31.7	43-A	54-B	64-C	75-D	86-E	97-F	107-G	118-H	128
8	102,500 (68.1)	—	—	—	—	—	—	—	—	—
10	89,950 (64)	39,200 (71.6)	39,700 (75.6)	—	—	—	—	—	—	—
12	79,900 (59.8)	39,200 (68.7)	39,700 (73.4)	40,300 (76.4)	34,100 (78.7)	—	—	—	—	—
15	64,350 (53.1)	39,200 (64.4)	39,700 (70.1)	40,300 (73.5)	34,100 (76.4)	22,650 (78.3)	—	—	—	—
20	47,050 (40.3)	39,200 (56.7)	39,700 (64.4)	40,300 (68.8)	34,100 (72.5)	22,650 (75)	17,800 (77.1)	14,700 (78.6)	—	—
25	30,750 (21.8)	31,750 (47.5)	32,200 (58)	32,450 (63.9)	30,100 (68.4)	22,650 (71.5)	17,800 (74.2)	14,700 (76.1)	12,900 (77.8)	9600 (78.9)
30	—	22,250 (37.3)	22,650 (51.3)	22,900 (58.6)	23,050 (64.2)	20,400 (68)	17,800 (71.2)	14,700 (73.5)	12,900 (75.6)	9600 (76.9)
35	—	16,500 (23.6)	16,950 (43.9)	17,200 (53.1)	17,350 (59.8)	17,450 (64.3)	16,300 (68)	14,700 (70.8)	12,900 (73.2)	9600 (74.8)
40	—	—	13,100 (35.2)	13,350 (47)	13,500 (55.1)	13,600 (60.5)	13,650 (64.7)	13,650 (68)	12,050 (70.8)	9600 (72.7)
45	—	—	10,350 (24)	10,650 (40.3)	10,800 (50)	10,900 (56.5)	11,000 (61.5)	11,050 (65)	11,100 (68.2)	9600 (70.6)
50	—	—	—	8560 (32.4)	8730 (44.6)	8850 (52.3)	8920 (58)	8970 (62)	9010 (65.8)	9040 (68.4)
55	—	—	—	6920 (22.2)	7110 (38.6)	7220 (47.8)	7300 (54.4)	7350 (59.2)	7390 (63.2)	7410 (65.9)
60	—	—	—	—	5800 (32.4)	5920 (43.3)	6000 (50.8)	6050 (56)	6090 (60.4)	6120 (63.3)
65	—	—	—	—	4730 (23.9)	4860 (37.9)	4940 (46.6)	4980 (52.4)	5020 (57.5)	5050 (60.6)
70	—	—	—	—	3820 (9.2)	3970 (31.8)	4050 (42.1)	4100 (48.7)	4130 (54.3)	4160 (57.9)
75	—	—	—	—	—	3210 (24.3)	3290 (37.2)	3340 (44.7)	3380 (51)	3410 (55)
80	—	—	—	—	—	2550 (12.8)	2650 (31.6)	2700 (40.5)	2740 (47.5)	2770 (52.1)
85	—	—	—	—	—	—	2080 (24.8)	2140 (35.8)	2180 (43.8)	2210 (49)
90	—	—	—	—	—	—	1590 (15.3)	1650 (30.4)	1690 (39.8)	1720 (45.7)
95	—	—	—	—	—	—	—	1220 (24)	1260 (35.4)	1290 (42.2)
100	—	—	—	—	—	—	—	830 (14.9)	880 (30.5)	910 (38.4)
105	—	—	—	—	—	—	—	—	530 (24.6)	570 (34.2)
Minimum boom angle (°) for indicated length (no load)							11	13	23	33
Maximum boom length (ft) at 0° (no load)							86			

NOTE: () Boom angles are in degrees.
#RCL operating code. Refer to RCL manual for operating instructions.

Boom Angle	Lifting Capacities at Zero Degree Boom Angle									
	Main Boom Length in Feet									
	31.7	43-A	54-B	64-C	75-D	86-E				
0°	12,900 (27.6)	7600 (38.8)	4850 (49.8)	3700 (59.8)	2200 (70.8)	1150 (81.8)	—	—	—	—

NOTE: () Reference radii in feet. 80094321A

THIS CHART IS ONLY A GUIDE AND SHOULD NOT BE USED TO OPERATE THE CRANE.

The individual crane's load chart, operating instructions and other instructional plates must be read and understood prior to operating the crane.

National Crane NTC55

25



AVAILABLE AT:

GIUFFRE.COM

GIUFFRE BROS CRANES INC.

6635 SOUTH 13TH ST. - MILWAUKEE, WI 53221
414-764-9200 • 877-321-3710

Load charts

 9,7 m – 39,0 m
(31.7 ft – 128 ft)

 Stowed

 1928 kg
(4250 lb)

 75%

 360°



 Pounds

Radius in feet	#4202										
	Main Boom Length in Feet										
	31.7	43-A	54-B	64-C	75-D	86-E	97-F	107-G	118-H	128	
8	101,000 (68.1)	—	—	—	—	—	—	—	—	—	
10	88,800 (64)	38,400 (71.6)	39,100 (75.6)	—	—	—	—	—	—	—	
12	78,750 (59.8)	38,400 (68.7)	39,100 (73.4)	39,800 (76.4)	33,650 (78.7)	—	—	—	—	—	
15	63,200 (53.1)	38,400 (64.4)	39,100 (70.1)	39,800 (73.5)	33,650 (76.4)	22,250 (78.3)	—	—	—	—	
20	45,900 (40.3)	38,400 (56.7)	39,100 (64.4)	39,800 (68.8)	33,650 (72.5)	22,250 (75)	17,450 (77.1)	14,400 (78.6)	—	—	
25	29,600 (21.8)	30,950 (47.5)	31,600 (58)	31,950 (63.9)	29,650 (68.4)	22,250 (71.5)	17,450 (74.2)	14,400 (76.1)	12,600 (77.8)	9350 (78.9)	
30	—	21,450 (37.3)	22,050 (51.3)	22,400 (58.6)	22,600 (64.2)	20,000 (68)	17,450 (71.2)	14,400 (73.5)	12,600 (75.6)	9350 (76.9)	
35	—	15,700 (23.6)	16,350 (43.9)	16,700 (53.1)	16,900 (59.8)	17,050 (64.3)	15,950 (68)	14,400 (70.8)	12,600 (73.2)	9350 (74.8)	
40	—	—	12,500 (35.2)	12,850 (47)	13,050 (55.1)	13,200 (60.5)	13,300 (64.7)	13,350 (68)	11,750 (70.8)	9350 (72.7)	
45	—	—	9750 (24)	10,150 (40.3)	10,350 (50)	10,500 (56.5)	10,650 (61.5)	10,750 (65)	10,800 (68.2)	9350 (70.6)	
50	—	—	—	8060 (32.4)	8280 (44.6)	8450 (52.3)	8570 (58)	8670 (62)	8710 (65.8)	8790 (68.4)	
55	—	—	—	6420 (22.2)	6660 (38.6)	6820 (47.8)	6950 (54.4)	7050 (59.2)	7090 (63.2)	7160 (65.9)	
60	—	—	—	—	5350 (32.4)	5520 (43.3)	5650 (50.8)	5750 (56)	5790 (60.4)	5870 (63.3)	
65	—	—	—	—	4280 (23.9)	4460 (37.9)	4590 (46.6)	4680 (52.4)	4720 (57.5)	4800 (60.6)	
70	—	—	—	—	3370 (9.2)	3570 (31.8)	3700 (42.1)	3800 (48.7)	3830 (54.3)	3910 (57.9)	
75	—	—	—	—	—	2810 (24.3)	2940 (37.2)	3040 (44.7)	3080 (51)	3160 (55)	
80	—	—	—	—	—	2150 (12.8)	2300 (31.6)	2400 (40.5)	2440 (47.5)	2520 (52.1)	
85	—	—	—	—	—	—	1730 (24.8)	1840 (35.8)	1880 (43.8)	1960 (49)	
90	—	—	—	—	—	—	—	1240 (15.3)	1350 (30.4)	1390 (39.8)	
95	—	—	—	—	—	—	—	—	920 (24)	960 (35.4)	
100	—	—	—	—	—	—	—	—	—	530 (14.9)	
									580 (30.5)	660 (38.4)	
Minimum boom angle (°) for indicated length (no load)							11	13	29	37	
Maximum boom length (ft) at 0° (no load)							86				

NOTE: () Boom angles are in degrees.
#RCL operating code. Refer to RCL manual for operating instructions.

Boom Angle	Lifting Capacities at Zero Degree Boom Angle									
	Main Boom Length in Feet									
	31.7	43-A	54-B	64-C	75-D	86-E				
0°	11,750 (27.6)	6800 (38.8)	4250 (49.8)	3200 (59.8)	1750 (70.8)	750 (81.8)	—	—	—	—

NOTE: () Reference radii in feet. 80094322A

THIS CHART IS ONLY A GUIDE AND SHOULD NOT BE USED TO OPERATE THE CRANE.
The individual crane's load chart, operating instructions and other instructional plates must be read and understood prior to operating the crane.

Load charts

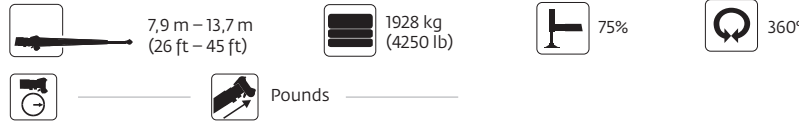

Radius in feet	**26 ft Length		45 ft Length	
	#4205	#4207	#4209	#4211
	0° OFFSET	30° OFFSET	0° OFFSET	30° OFFSET
35	5200 (76.9)	—	—	—
40	5200 (75.3)	—	3700 (77.3)	—
45	5200 (73.6)	—	3700 (75.8)	—
50	5200 (71.9)	4800 (77.4)	3700 (74.4)	—
55	5200 (70.1)	4800 (75.6)	3700 (72.9)	—
60	5200 (68.4)	4800 (73.7)	3700 (71.4)	—
65	4620 (66.7)	4800 (71.7)	3700 (69.9)	2500 (77)
70	3720 (64.7)	4590 (69.7)	3700 (68.4)	2500 (75.2)
75	2970 (62.6)	3740 (67.5)	3670 (66.9)	2500 (73.5)
80	2320 (60.5)	3010 (65.2)	3020 (65.4)	2500 (71.7)
85	1760 (58.3)	2380 (62.9)	2450 (63.8)	2500 (69.8)
90	1270 (56.1)	1830 (60.5)	1950 (61.9)	2500 (67.9)
95	840 (53.8)	1330 (58.1)	1510 (59.9)	2430 (65.9)
100	450 (51.2)	900 (55.4)	1120 (57.8)	1950 (63.9)
105	—	500 (52.5)	770 (55.6)	1530 (61.7)
110	—	—	460 (53.5)	1150 (59.5)
115	—	—	—	800 (57.1)
120	—	—	—	480 (54.7)
Min. boom angle for indicated length (no load)	50°	51°	52°	53°
Max. boom length at 0° boom angle (no load)	64 ft		64 ft	

NOTE: () Boom angles are in degrees. 80094325A

#RCL operating code. Refer to RCL manual for instructions.

**26 ft. capacities are applicable to both 26' fixed and 26' tele extension.

Boom extension capacity notes:

- 26 ft and 45 ft extension lengths may be used for single line lifting service.
- Radii listed are for a fully extended boom with the boom extension erected. For main boom lengths less than fully extended, the rated loads are determined by boom angle. Use only the column which corresponds to the boom extension length and offset for which the machine is configured. For boom angles not shown, use the rating of the next lower boom angle.
Warning: Operation of this machine with heavier loads than the capacities listed is strictly prohibited. Machine tipping with boom extension occurs rapidly and without advance warning.
- Boom angle is the angle above or below horizontal of the longitudinal axis of the boom base section after lifting rated load.
- Capacities listed are with outriggers properly extended and vertical jacks set only.

THIS CHART IS ONLY A GUIDE AND SHOULD NOT BE USED TO OPERATE THE CRANE.

The individual crane's load chart, operating instructions and other instructional plates must be read and understood prior to operating the crane.

National Crane NTC55

27

Load charts

9,7 m – 39,0 m
(31.7 ft – 128 ft)

1360 kg
(3000 lb)

100%

360°



Pounds

Radius in feet	#1001										
	Main Boom Length in Feet										
	31.7	43-A	54-B	64-C	75-D	86-E	97-F	107-G	118-H	128	
8	100,000 (68.1)	—	—	—	—	—	—	—	—	—	
10	92,250 (64)	39,200 (71.6)	39,700 (75.6)	—	—	—	—	—	—	—	
12	80,100 (59.8)	39,200 (68.7)	39,700 (73.4)	40,300 (76.4)	34,100 (78.7)	—	—	—	—	—	
15	63,450 (53.1)	39,200 (64.4)	39,700 (70.1)	40,300 (73.5)	34,100 (76.4)	22,650 (78.3)	—	—	—	—	
20	46,300 (40.3)	39,200 (56.7)	39,700 (64.4)	40,300 (68.8)	34,100 (72.5)	22,650 (75)	17,800 (77.1)	14,700 (78.6)	—	—	
25	31,650 (21.8)	36,500 (47.5)	36,950 (58)	37,150 (63.9)	30,100 (68.4)	22,650 (71.5)	17,800 (74.2)	14,700 (76.1)	12,900 (77.8)	—	
30	—	28,950 (37.3)	29,400 (51.3)	29,700 (58.6)	27,100 (64.2)	20,400 (68)	17,800 (71.2)	14,700 (73.5)	12,900 (75.6)	9600 (76.9)	
35	—	22,300 (23.6)	23,900 (43.9)	24,300 (53.1)	24,550 (59.8)	18,500 (64.3)	16,300 (68)	14,700 (70.8)	12,900 (73.2)	9600 (74.8)	
40	—	—	18,600 (35.2)	18,950 (47)	19,250 (55.1)	17,050 (60.5)	15,100 (64.7)	13,650 (68)	12,050 (70.8)	9600 (72.7)	
45	—	—	14,800 (24)	15,150 (40.3)	15,450 (50)	15,650 (56.5)	14,000 (61.5)	12,550 (65)	11,300 (68.2)	9600 (70.6)	
50	—	—	—	12,350 (32.4)	12,600 (44.6)	12,800 (52.3)	12,850 (58)	11,750 (62)	10,650 (65.8)	9600 (68.4)	
55	—	—	—	10,300 (22.2)	10,600 (38.6)	10,800 (47.8)	11,000 (54.4)	10,950 (59.2)	10,000 (63.2)	8750 (65.9)	
60	—	—	—	—	8850 (32.4)	9050 (43.3)	9250 (50.8)	9400 (56)	9400 (60.4)	7850 (63.3)	
65	—	—	—	—	7450 (23.9)	7650 (37.9)	7800 (46.6)	7950 (52.4)	8100 (57.5)	7000 (60.6)	
70	—	—	—	—	*4650 (9.2)	6500 (31.8)	6650 (42.1)	6800 (48.7)	6900 (54.3)	6300 (57.9)	
75	—	—	—	—	—	5500 (24.3)	5650 (37.2)	5800 (44.7)	5900 (51)	5700 (55)	
80	—	—	—	—	—	*4400 (12.8)	4800 (31.6)	4950 (40.5)	5050 (47.5)	5150 (52.1)	
85	—	—	—	—	—	—	4100 (24.8)	4200 (35.8)	4300 (43.8)	4400 (49)	
90	—	—	—	—	—	—	3450 (15.3)	3550 (30.4)	3650 (39.8)	3750 (45.7)	
95	—	—	—	—	—	—	—	3000 (24)	3100 (35.4)	3200 (42.2)	
100	—	—	—	—	—	—	—	2500 (14.9)	2600 (30.5)	2700 (38.4)	
105	—	—	—	—	—	—	—	—	2150 (24.6)	2250 (34.2)	
110	—	—	—	—	—	—	—	—	1750 (16.8)	1800 (29.5)	
115	—	—	—	—	—	—	—	—	—	1450 (23.7)	
120	—	—	—	—	—	—	—	—	—	*1100 (15.8)	
Minimum boom angle (°) for indicated length (no load)							0	5	8	10	
Maximum boom length (ft) at 0° (no load)							97				

NOTE: () Boom angles are in degrees.
*Loads are structurally limited.
#RCL operating code. Refer to RCL manual for operating instructions.

Boom Angle	Lifting Capacities at Zero Degree Boom Angle									
	Main Boom Length in Feet									
	31.7	43-A	54-B	64-C	75-D	86-E	97-F	107-G	118-H	128
0°	12,900 (27.6)	7600 (38.8)	4850 (49.8)	3700 (59.8)	2200 (70.8)	1150 (81.8)	—	—	—	—

NOTE: () Reference radii in feet. 80083175

THIS CHART IS ONLY A GUIDE AND SHOULD NOT BE USED TO OPERATE THE CRANE.
The individual crane's load chart, operating instructions and other instructional plates must be read and understood prior to operating the crane.

To learn more about this model, call 414-764-9200 or visit giuffre.com today!

Load charts

9,7 m – 39,0 m (31.7 ft – 128 ft)
 Stowed
 1360 kg (3000 lb)
 100%
 360°

Pounds

Radius in feet	#1002									
	Main Boom Length in Feet									
	31.7	43-A	54-B	64-C	75-D	86-E	97-F	107-G	118-H	128
8	98,850 (68.1)	—	—	—	—	—	—	—	—	—
10	91,100 (64)	38,400 (71.6)	39,100 (75.6)	—	—	—	—	—	—	—
12	78,950 (59.8)	38,400 (68.7)	39,100 (73.4)	39,800 (76.4)	33,650 (78.7)	—	—	—	—	—
15	62,300 (53.1)	38,400 (64.4)	39,100 (70.1)	39,800 (73.5)	33,650 (76.4)	22,250 (78.3)	—	—	—	—
20	45,150 (40.3)	38,400 (56.7)	39,100 (64.4)	39,800 (68.8)	33,650 (72.5)	22,250 (75)	17,450 (77.1)	14,400 (78.6)	—	—
25	30,500 (21.8)	35,700 (47.5)	36,350 (58)	36,650 (63.9)	29,650 (68.4)	22,250 (71.5)	17,450 (74.2)	14,400 (76.1)	12,600 (77.8)	—
30	—	28,150 (37.3)	28,800 (51.3)	29,200 (58.6)	26,650 (64.2)	20,000 (68)	17,450 (71.2)	14,400 (73.5)	12,600 (75.6)	9350 (76.9)
35	—	21,500 (23.6)	23,300 (43.9)	23,800 (53.1)	24,100 (59.8)	18,100 (64.3)	15,950 (68)	14,400 (70.8)	12,600 (73.2)	9350 (74.8)
40	—	—	18,000 (35.2)	18,450 (47)	18,800 (55.1)	16,650 (60.5)	14,750 (64.7)	13,350 (68)	11,750 (70.8)	9350 (72.7)
45	—	—	14,200 (24)	14,650 (40.3)	15,000 (50)	15,250 (56.5)	13,650 (61.5)	12,250 (65)	11,000 (68.2)	9350 (70.6)
50	—	—	—	11,850 (32.4)	12,150 (44.6)	12,400 (52.3)	12,500 (58)	11,450 (62)	10,350 (65.8)	9350 (68.4)
55	—	—	—	9800 (22.2)	10,150 (38.6)	10,400 (47.8)	10,650 (54.4)	10,650 (59.2)	9700 (63.2)	8500 (65.9)
60	—	—	—	—	8400 (32.4)	8650 (43.3)	8900 (50.8)	9100 (56)	9100 (60.4)	7600 (63.3)
65	—	—	—	—	7000 (23.9)	7250 (37.9)	7450 (46.6)	7650 (52.4)	7800 (57.5)	6750 (60.6)
70	—	—	—	—	*4200 (9.2)	6100 (31.8)	6300 (42.1)	6500 (48.7)	6600 (54.3)	6050 (57.9)
75	—	—	—	—	—	5100 (24.3)	5300 (37.2)	5500 (44.7)	5600 (51)	5450 (55)
80	—	—	—	—	—	*4000 (12.8)	4450 (31.6)	4650 (40.5)	4750 (47.5)	4900 (52.1)
85	—	—	—	—	—	—	3750 (24.8)	3900 (35.8)	4000 (43.8)	4150 (49)
90	—	—	—	—	—	—	3100 (15.3)	3250 (30.4)	3350 (39.8)	3500 (45.7)
95	—	—	—	—	—	—	—	2700 (24)	2800 (35.4)	2950 (42.2)
100	—	—	—	—	—	—	—	2200 (14.9)	2300 (30.5)	2450 (38.4)
105	—	—	—	—	—	—	—	—	1850 (24.6)	2000 (34.2)
110	—	—	—	—	—	—	—	—	1450 (16.8)	1550 (29.5)
115	—	—	—	—	—	—	—	—	—	1200 (23.7)
120	—	—	—	—	—	—	—	—	—	*850 (15.8)
Minimum boom angle (°) for indicated length (no load)							0	5	8	10
Maximum boom length (ft) at 0° (no load)							97			

NOTE: () Boom angles are in degrees.
 *Loads are structurally limited.
 #RCL operating code. Refer to RCL manual for operating instructions.

Boom Angle	Lifting Capacities at Zero Degree Boom Angle									
	Main Boom Length in Feet									
	31.7	43-A	54-B	64-C	75-D	86-E				
0°	11,750 (27.6)	6800 (38.8)	4250 (49.8)	3200 (59.8)	1750 (70.8)	750 (81.8)	—	—	—	—

NOTE: () Reference radii in feet. 80083176

THIS CHART IS ONLY A GUIDE AND SHOULD NOT BE USED TO OPERATE THE CRANE.
 The individual crane's load chart, operating instructions and other instructional plates must be read and understood prior to operating the crane.



AVAILABLE AT:

GIUFFRE.COM

GIUFFRE BROS CRANES INC.

6635 SOUTH 13TH ST. - MILWAUKEE, WI 53221
 414-764-9200 • 877-321-3710

Load charts

 9,7 m – 39,0 m
(31.7 ft – 128 ft)

 1360 kg
(3000 lb)

 100%

 Over Rear



 Pounds

Radius in feet	#1003									
	Main Boom Length in Feet									
	31.7	43-A	54-B	64-C	75-D	86-E	97-F	107-G	118-H	128
8	100,000 (68.1)	—	—	—	—	—	—	—	—	—
10	92,250 (64)	39,200 (71.6)	39,700 (75.6)	—	—	—	—	—	—	—
12	80,100 (59.8)	39,200 (68.7)	39,700 (73.4)	40,300 (76.4)	34,100 (78.7)	—	—	—	—	—
15	63,450 (53.1)	39,200 (64.4)	39,700 (70.1)	40,300 (73.5)	34,100 (76.4)	22,650 (78.3)	—	—	—	—
20	46,300 (40.3)	39,200 (56.7)	39,700 (64.4)	40,300 (68.8)	34,100 (72.5)	22,650 (75)	17,800 (77.1)	14,700 (78.6)	—	—
25	31,650 (21.8)	36,500 (47.5)	36,950 (58)	37,150 (63.9)	30,100 (68.4)	22,650 (71.5)	17,800 (74.2)	14,700 (76.1)	12,900 (77.8)	9600 (78.9)
30	—	28,950 (37.3)	29,400 (51.3)	29,700 (58.6)	27,100 (64.2)	20,400 (68)	17,800 (71.2)	14,700 (73.5)	12,900 (75.6)	9600 (76.9)
35	—	22,300 (23.6)	24,000 (43.9)	24,300 (53.1)	24,550 (59.8)	18,500 (64.3)	16,300 (68)	14,700 (70.8)	12,900 (73.2)	9600 (74.8)
40	—	—	20,000 (35.2)	20,300 (47)	20,550 (55.1)	17,050 (60.5)	15,100 (64.7)	13,650 (68)	12,050 (70.8)	9600 (72.7)
45	—	—	16,400 (24)	16,800 (40.3)	17,050 (50)	15,800 (56.5)	14,000 (61.5)	12,550 (65)	11,300 (68.2)	9600 (70.6)
50	—	—	—	13,900 (32.4)	14,150 (44.6)	14,350 (52.3)	12,850 (58)	11,750 (62)	10,650 (65.8)	9600 (68.4)
55	—	—	—	11,650 (22.2)	11,900 (38.6)	12,100 (47.8)	12,000 (54.4)	10,950 (59.2)	10,000 (63.2)	8750 (65.9)
60	—	—	—	—	10,200 (32.4)	10,400 (43.3)	10,550 (50.8)	10,300 (56)	9400 (60.4)	7850 (63.3)
65	—	—	—	—	8700 (23.9)	8900 (37.9)	9050 (46.6)	9200 (52.4)	8850 (57.5)	7000 (60.6)
70	—	—	—	—	*4650 (9.2)	7650 (31.8)	7850 (42.1)	7950 (48.7)	8100 (54.3)	6300 (57.9)
75	—	—	—	—	—	6600 (24.3)	6750 (37.2)	6900 (44.7)	7000 (51)	5700 (55)
80	—	—	—	—	—	*4400 (12.8)	5850 (31.6)	6000 (40.5)	6100 (47.5)	5150 (52.1)
85	—	—	—	—	—	—	5100 (24.8)	5200 (35.8)	5300 (43.8)	4650 (49)
90	—	—	—	—	—	—	*3850 (15.3)	4500 (30.4)	4600 (39.8)	4150 (45.7)
95	—	—	—	—	—	—	—	3900 (24)	4000 (35.4)	3700 (42.2)
100	—	—	—	—	—	—	—	*2800 (14.9)	3450 (30.5)	3300 (38.4)
105	—	—	—	—	—	—	—	—	2950 (24.6)	3000 (34.2)
110	—	—	—	—	—	—	—	—	*2400 (16.8)	2600 (29.5)
115	—	—	—	—	—	—	—	—	—	*1900 (23.7)
120	—	—	—	—	—	—	—	—	—	*1100 (15.8)
Minimum boom angle (°) for indicated length (no load)							0	5	8	10
Maximum boom length (ft) at 0° (no load)							97			

NOTE: () Boom angles are in degrees.
*Loads are structurally limited.
#RCL operating code. Refer to RCL manual for operating instructions.

Boom Angle	Lifting Capacities at Zero Degree Boom Angle									
	Main Boom Length in Feet									
	31.7	43-A	54-B	64-C	75-D	86-E	97-F	107-G	118-H	128
0°	12,900 (27.6)	7600 (38.8)	4850 (49.8)	3700 (59.8)	2200 (70.8)	1150 (81.8)	—	—	—	—

NOTE: () Reference radii in feet. 80083179

THIS CHART IS ONLY A GUIDE AND SHOULD NOT BE USED TO OPERATE THE CRANE.
The individual crane's load chart, operating instructions and other instructional plates must be read and understood prior to operating the crane.

Load charts

9,7 m – 39,0 m (31.7 ft – 128 ft)
 Stowed
 1360 kg (3000 lb)
 100%
 Over Rear

Pounds

Radius in feet	#1004									
	Main Boom Length in Feet									
	31.7	43-A	54-B	64-C	75-D	86-E	97-F	107-G	118-H	128
8	98,850 (68.1)	—	—	—	—	—	—	—	—	—
10	91,100 (64)	38,400 (71.6)	39,100 (75.6)	—	—	—	—	—	—	—
12	78,950 (59.8)	38,400 (68.7)	39,100 (73.4)	39,800 (76.4)	33,650 (78.7)	—	—	—	—	—
15	62,300 (53.1)	38,400 (64.4)	39,100 (70.1)	39,800 (73.5)	33,650 (76.4)	22,250 (78.3)	—	—	—	—
20	45,150 (40.3)	38,400 (56.7)	39,100 (64.4)	39,800 (68.8)	33,650 (72.5)	22,250 (75)	17,450 (77.1)	14,400 (78.6)	—	—
25	30,500 (21.8)	35,700 (47.5)	36,350 (58)	36,650 (63.9)	29,650 (68.4)	22,250 (71.5)	17,450 (74.2)	14,400 (76.1)	12,600 (77.8)	—
30	—	28,150 (37.3)	28,800 (51.3)	29,200 (58.6)	26,650 (64.2)	20,000 (68)	17,450 (71.2)	14,400 (73.5)	12,600 (75.6)	9350 (76.9)
35	—	21,500 (23.6)	23,400 (43.9)	23,800 (53.1)	24,100 (59.8)	18,100 (64.3)	15,950 (68)	14,400 (70.8)	12,600 (73.2)	9350 (74.8)
40	—	—	19,400 (35.2)	19,800 (47)	20,100 (55.1)	16,650 (60.5)	14,750 (64.7)	13,350 (68)	11,750 (70.8)	9350 (72.7)
45	—	—	15,800 (24)	16,300 (40.3)	16,600 (50)	15,400 (56.5)	13,650 (61.5)	12,250 (65)	11,000 (68.2)	9350 (70.6)
50	—	—	—	13,400 (32.4)	13,700 (44.6)	13,950 (52.3)	12,500 (58)	11,450 (62)	10,350 (65.8)	9350 (68.4)
55	—	—	—	11,150 (22.2)	11,450 (38.6)	11,700 (47.8)	11,650 (54.4)	10,650 (59.2)	9700 (63.2)	8500 (65.9)
60	—	—	—	—	9750 (32.4)	10,000 (43.3)	10,200 (50.8)	10,000 (56)	9100 (60.4)	7600 (63.3)
65	—	—	—	—	8250 (23.9)	8500 (37.9)	8700 (46.6)	8900 (52.4)	8550 (57.5)	6750 (60.6)
70	—	—	—	—	*4200 (9.2)	7250 (31.8)	7500 (42.1)	7650 (48.7)	7800 (54.3)	6050 (57.9)
75	—	—	—	—	—	6200 (24.3)	6400 (37.2)	6600 (44.7)	6700 (51)	5450 (55)
80	—	—	—	—	—	*4000 (12.8)	5500 (31.6)	5700 (40.5)	5800 (47.5)	4900 (52.1)
85	—	—	—	—	—	—	4750 (24.8)	4900 (35.8)	5000 (43.8)	4400 (49)
90	—	—	—	—	—	—	*3500 (15.3)	4200 (30.4)	4300 (39.8)	3900 (45.7)
95	—	—	—	—	—	—	—	3600 (24)	3700 (35.4)	3450 (42.2)
100	—	—	—	—	—	—	—	*2500 (14.9)	3150 (30.5)	3050 (38.4)
105	—	—	—	—	—	—	—	—	2650 (24.6)	2750 (34.2)
110	—	—	—	—	—	—	—	—	*2100 (16.8)	2350 (29.5)
115	—	—	—	—	—	—	—	—	—	*1650 (23.7)
120	—	—	—	—	—	—	—	—	—	*850 (15.8)
Minimum boom angle (°) for indicated length (no load)							0	5	8	10
Maximum boom length (ft) at 0° (no load)							97			

NOTE: () Boom angles are in degrees.
 *Loads are structurally limited.
 #RCL operating code. Refer to RCL manual for operating instructions.

Boom Angle	Lifting Capacities at Zero Degree Boom Angle									
	Main Boom Length in Feet									
	31.7	43-A	54-B	64-C	75-D	86-E				
0°	11,750 (27.6)	6800 (38.8)	4250 (49.8)	3200 (59.8)	1750 (70.8)	750 (81.8)	—	—	—	—

NOTE: () Reference radii in feet. 80083180

THIS CHART IS ONLY A GUIDE AND SHOULD NOT BE USED TO OPERATE THE CRANE.
 The individual crane's load chart, operating instructions and other instructional plates must be read and understood prior to operating the crane.



Load charts



7,9 m – 13,7 m
(26 ft – 45 ft)



1360 kg
(3000 lb)



100%



360°



Pounds

Radius in feet	**26 ft Length		45 ft Length	
	#1005	#1007	#1009	#1011
	0° OFFSET	30° OFFSET	0° OFFSET	30° OFFSET
35	5200 (76.9)	—	—	—
40	5200 (75.3)	—	3700 (77.3)	—
45	5200 (73.6)	—	3700 (75.8)	—
50	5200 (71.9)	4800 (77.4)	3700 (74.4)	—
55	5200 (70.1)	4800 (75.6)	3700 (72.9)	—
60	5200 (68.4)	4800 (73.7)	3700 (71.4)	—
65	5200 (66.7)	4800 (71.7)	3700 (69.9)	2500 (77)
70	4850 (64.7)	4650 (69.7)	3700 (68.4)	2500 (75.2)
75	4500 (62.6)	4400 (67.5)	3700 (66.9)	2500 (73.5)
80	4250 (60.5)	4150 (65.2)	3700 (65.4)	2500 (71.7)
85	3450 (58.3)	4000 (62.9)	3700 (63.8)	2500 (69.8)
90	3450 (56.1)	3800 (60.5)	3550 (61.9)	2500 (67.9)
95	3000 (53.8)	3550 (58.1)	3250 (59.9)	2500 (65.9)
100	2450 (51.2)	2950 (55.4)	3000 (57.8)	2500 (63.9)
105	2000 (48.4)	2450 (52.5)	2700 (55.6)	2450 (61.7)
110	1600 (45.5)	1950 (49.5)	2400 (53.5)	2400 (59.5)
115	1200 (42.5)	1500 (46.3)	2000 (51.2)	2350 (57.1)
120	850 (39.3)	1100 (42.7)	1650 (48.7)	2200 (54.7)
125	550 (35.8)	750 (38.9)	1300 (46)	1800 (52.1)
130	—	—	1000 (43.3)	1450 (49.1)
135	—	—	700 (40.4)	1050 (45.9)
140	—	—	450 (37.2)	800 (42.3)
145	—	—	—	500 (38.2)
Min. boom angle for indicated length (no load)	34°	34°	36°	36°
Max. boom length at 0° boom angle (no load)	64 ft		64 ft	

NOTE: () Boom angles are in degrees. 80084533
#RCL operating code. Refer to RCL manual for instructions.
*Loads are structurally limited.
**26 ft. capacities are applicable to both 26' fixed and 26' tele extension.

Boom extension capacity notes:

- 26 ft. and 45 ft. extension lengths may be used for single line lifting service.
- Radii listed are for a fully extended boom with the boom extension erected. For main boom lengths less than fully extended, the rated loads are determined by boom angle. Use only the column which corresponds to the boom extension length and offset for which the machine is configured. For boom angles not shown, use the rating of the next lower boom angle.
WARNING: Operation of this machine with heavier loads than the capacities listed is strictly prohibited. Machine tipping with boom extension occurs rapidly and without advance warning.
- Boom angle is the angle above or below horizontal of the longitudinal axis of the boom base section after lifting rated load.
- Capacities listed are with outriggers properly extended and vertical jacks set only.

THIS CHART IS ONLY A GUIDE AND SHOULD NOT BE USED TO OPERATE THE CRANE.
The individual crane's load chart, operating instructions and other instructional plates must be read and understood prior to operating the crane.

Load charts



Radius in feet	**26 ft Length		45 ft Length	
	#1006	#1008	#1010	#1012
	0° OFFSET	30° OFFSET	0° OFFSET	30° OFFSET
35	5200 (76.9)	—	—	—
40	5200 (75.3)	—	3700 (77.3)	—
45	5200 (73.6)	—	3700 (75.8)	—
50	5200 (71.9)	4800 (77.4)	3700 (74.4)	—
55	5200 (70.1)	4800 (75.6)	3700 (72.9)	—
60	5200 (68.4)	4800 (73.7)	3700 (71.4)	—
65	5200 (66.7)	4800 (71.7)	3700 (69.9)	2500 (77)
70	4850 (64.7)	4650 (69.7)	3700 (68.4)	2500 (75.2)
75	4500 (62.6)	4400 (67.5)	3700 (66.9)	2500 (73.5)
80	4250 (60.5)	4150 (65.2)	3700 (65.4)	2500 (71.7)
85	3950 (58.3)	4000 (62.9)	3700 (63.8)	2500 (69.8)
90	3800 (56.1)	3800 (60.5)	3550 (61.9)	2500 (67.9)
95	3650 (53.8)	3650 (58.1)	3250 (59.9)	2500 (65.9)
100	3150 (51.2)	3350 (55.4)	3000 (57.8)	2500 (63.9)
105	2600 (48.4)	2900 (52.5)	2700 (55.6)	2450 (61.7)
110	2100 (45.5)	2550 (49.5)	2500 (53.5)	2400 (59.5)
115	1700 (42.5)	2150 (46.3)	2300 (51.2)	2350 (57.1)
120	1350 (39.3)	1650 (42.7)	2050 (48.7)	2300 (54.7)
125	950 (35.8)	1200 (38.9)	1750 (46)	2250 (52.1)
130	650 (32.1)	850 (34.8)	1500 (43.3)	2100 (49.1)
135	—	450 (30)	1200 (40.4)	1700 (45.9)
140	—	—	900 (37.2)	*1350 (42.3)
145	—	—	650 (33.9)	*900 (38.2)
150	—	—	—	*600 (33.9)
Min. boom angle for indicated length (no load)	29°	30°	30°	31°
Max. boom length at 0° boom angle (no load)	64 ft		64 ft	

NOTE: () Boom angles are in degrees. 80084534
 #RCL operating code. Refer to RCL manual for instructions.
 *Loads are structurally limited.
 **26 ft capacities are applicable to both 26 ft fixed and 26 ft tele extension

Boom extension capacity notes:

- 26 ft and 45 ft extension lengths may be used for single line lifting service.
- Radii listed are for a fully extended boom with the boom extension erected. For main boom lengths less than fully extended, the rated loads are determined by boom angle. Use only the column which corresponds to the boom extension length and offset for which the machine is configured. For boom angles not shown, use the rating of the next lower boom angle.
Warning: Operation of this machine with heavier loads than the capacities listed is strictly prohibited. Machine tipping with boom extension occurs rapidly and without advance warning.
- Boom angle is the angle above or below horizontal of the longitudinal axis of the boom base section after lifting rated load.
- Capacities listed are with outriggers properly extended and vertical jacks set only.

THIS CHART IS ONLY A GUIDE AND SHOULD NOT BE USED TO OPERATE THE CRANE.

The individual crane's load chart, operating instructions and other instructional plates must be read and understood prior to operating the crane.

Load charts

 9,7 m – 39,0 m
(31.7 ft – 128 ft)

 1360 kg
(3000 lb)

 75%

 360°



Pounds

Radius in feet	#1201									
	Main Boom Length in Feet									
	31.7	43-A	54-B	64-C	75-D	86-E	97-F	107-G	118-H	128
8	102,000 (68.1)	—	—	—	—	—	—	—	—	—
10	89,650 (64)	39,200 (71.6)	39,700 (75.6)	—	—	—	—	—	—	—
12	79,650 (59.8)	39,200 (68.7)	39,700 (73.4)	40,300 (76.4)	34,100 (78.7)	—	—	—	—	—
15	63,550 (53.1)	39,200 (64.4)	39,700 (70.1)	40,300 (73.5)	34,100 (76.4)	22,650 (78.3)	—	—	—	—
20	46,150 (40.3)	39,200 (56.7)	39,700 (64.4)	40,300 (68.8)	34,100 (72.5)	22,650 (75)	17,800 (77.1)	14,700 (78.6)	—	—
25	28,550 (21.8)	29,550 (47.5)	30,000 (58)	30,250 (63.9)	30,100 (68.4)	22,650 (71.5)	17,800 (74.2)	14,700 (76.1)	12,900 (77.8)	9600 (78.9)
30	—	20,600 (37.3)	21,100 (51.3)	21,300 (58.6)	21,500 (64.2)	20,400 (68)	17,800 (71.2)	14,700 (73.5)	12,900 (75.6)	9600 (76.9)
35	—	15,200 (23.6)	15,650 (43.9)	15,850 (53.1)	16,050 (59.8)	16,150 (64.3)	16,200 (68)	14,700 (70.8)	12,900 (73.2)	9600 (74.8)
40	—	—	12,000 (35.2)	12,250 (47)	12,400 (55.1)	12,500 (60.5)	12,550 (64.7)	12,600 (68)	12,050 (70.8)	9600 (72.7)
45	—	—	9440 (24)	9700 (40.3)	9870 (50)	9990 (56.5)	10,050 (61.5)	10,100 (65)	10,150 (68.2)	9600 (70.6)
50	—	—	—	7730 (32.4)	7910 (44.6)	8020 (52.3)	8100 (58)	8140 (62)	8180 (65.8)	8210 (68.4)
55	—	—	—	6190 (22.2)	6370 (38.6)	6490 (47.8)	6560 (54.4)	6610 (59.2)	6650 (63.2)	6680 (65.9)
60	—	—	—	—	5140 (32.4)	5260 (43.3)	5340 (50.8)	5390 (56)	5420 (60.4)	5450 (63.3)
65	—	—	—	—	4130 (23.9)	4250 (37.9)	4330 (46.6)	4380 (52.4)	4420 (57.5)	4450 (60.6)
70	—	—	—	—	3270 (9.2)	3410 (31.8)	3490 (42.1)	3540 (48.7)	3580 (54.3)	3610 (57.9)
75	—	—	—	—	—	2700 (24.3)	2780 (37.2)	2840 (44.7)	2870 (51)	2900 (55)
80	—	—	—	—	—	2080 (12.8)	2170 (31.6)	2230 (40.5)	2270 (47.5)	2300 (52.1)
85	—	—	—	—	—	—	1640 (24.8)	1700 (35.8)	1740 (43.8)	1770 (49)
90	—	—	—	—	—	—	1170 (15.3)	1240 (30.4)	1280 (39.8)	1310 (45.7)
95	—	—	—	—	—	—	—	830 (24)	870 (35.4)	900 (42.2)
100	—	—	—	—	—	—	—	—	510 (30.5)	540 (38.4)
Minimum boom angle (°) for indicated length (no load)							11	22	29	37
Maximum boom length (ft) at 0° boom angle (no load)							86			

NOTE: () Boom angles are in degrees.
*Loads are structurally limited.
#RCL operating code. Refer to RCL manual for operating instructions.

Boom Angle	Lifting Capacities at Zero Degree Boom Angle									
	Main Boom Length in Feet									
	31.7	43-A	54-B	64-C	75-D	86-E				
0°	12,900 (27.6)	7600 (38.8)	4850 (49.8)	3700 (59.8)	2200 (70.8)	1150 (81.8)	—	—	—	—

NOTE: () Reference radii in feet. 80094334A

THIS CHART IS ONLY A GUIDE AND SHOULD NOT BE USED TO OPERATE THE CRANE.
The individual crane's load chart, operating instructions and other instructional plates must be read and understood prior to operating the crane.

Load charts

9,7 m – 39,0 m (31.7 ft – 128 ft)
 Stowed
 1360 kg (3000 lb)
 75%
 360°

Pounds

Radius in feet	#1202									
	Main Boom Length in Feet									
	31.7	43-A	54-B	64-C	75-D	86-E	97-F	107-G	118-H	128
8	100,500 (68.1)	—	—	—	—	—	—	—	—	—
10	88,500 (64)	38,400 (71.6)	39,100 (75.6)	—	—	—	—	—	—	—
12	78,500 (59.8)	38,400 (68.7)	39,100 (73.4)	39,800 (76.4)	33,650 (78.7)	—	—	—	—	—
15	62,400 (53.1)	38,400 (64.4)	39,100 (70.1)	39,800 (73.5)	33,650 (76.4)	22,250 (78.3)	—	—	—	—
20	45,000 (40.3)	38,400 (56.7)	39,100 (64.4)	39,800 (68.8)	33,650 (72.5)	22,250 (75)	17,450 (77.1)	14,400 (78.6)	—	—
25	27,400 (21.8)	28,750 (47.5)	29,400 (58)	29,750 (63.9)	29,650 (68.4)	22,250 (71.5)	17,450 (74.2)	14,400 (76.1)	12,600 (77.8)	9350 (78.9)
30	—	19,800 (37.3)	20,500 (51.3)	20,800 (58.6)	21,050 (64.2)	20,000 (68)	17,450 (71.2)	14,400 (73.5)	12,600 (75.6)	9350 (76.9)
35	—	14,400 (23.6)	15,050 (43.9)	15,350 (53.1)	15,600 (59.8)	15,750 (64.3)	15,850 (68)	14,400 (70.8)	12,600 (73.2)	9350 (74.8)
40	—	—	11,400 (35.2)	11,750 (47)	11,950 (55.1)	12,100 (60.5)	12,200 (64.7)	12,300 (68)	11,750 (70.8)	9350 (72.7)
45	—	—	8840 (24)	9200 (40.3)	9420 (50)	9590 (56.5)	9700 (61.5)	9800 (65)	9850 (68.2)	9350 (70.6)
50	—	—	—	7230 (32.4)	7460 (44.6)	7620 (52.3)	7750 (58)	7840 (62)	7880 (65.8)	7960 (68.4)
55	—	—	—	5690 (22.2)	5920 (38.6)	6090 (47.8)	6210 (54.4)	6310 (59.2)	6350 (63.2)	6430 (65.9)
60	—	—	—	—	4690 (32.4)	4860 (43.3)	4990 (50.8)	5090 (56)	5120 (60.4)	5200 (63.3)
65	—	—	—	—	3680 (23.9)	3850 (37.9)	3980 (46.6)	4080 (52.4)	4120 (57.5)	4200 (60.6)
70	—	—	—	—	2820 (9.2)	3010 (31.8)	3140 (42.1)	3240 (48.7)	3280 (54.3)	3360 (57.9)
75	—	—	—	—	—	2300 (24.3)	2430 (37.2)	2540 (44.7)	2570 (51)	2650 (55)
80	—	—	—	—	—	1680 (12.8)	1820 (31.6)	1930 (40.5)	1970 (47.5)	2050 (52.1)
85	—	—	—	—	—	—	1290 (24.8)	1400 (35.8)	1440 (43.8)	1520 (49)
90	—	—	—	—	—	—	820 (15.3)	940 (30.4)	980 (39.8)	1060 (45.7)
95	—	—	—	—	—	—	—	530 (24)	570 (35.4)	650 (42.2)
Minimum boom angle (°) for indicated length (no load)							11	22	34	41
Maximum boom length (ft) at 0° boom angle (no load)								86		

NOTE: () Boom angles are in degrees.
 *Loads are structurally limited.
 #RCL operating code. Refer to RCL manual for operating instructions.

Boom Angle	Lifting Capacities at Zero Degree Boom Angle									
	Main Boom Length in Feet									
	31.7	43-A	54-B	64-C	75-D	86-E				
0°	11,750 (27.6)	6800 (38.8)	4250 (49.8)	3200 (59.8)	1750 (70.8)	750 (81.8)	—	—	—	—

NOTE: () Reference radii in feet. 80094335A

THIS CHART IS ONLY A GUIDE AND SHOULD NOT BE USED TO OPERATE THE CRANE.
 The individual crane's load chart, operating instructions and other instructional plates must be read and understood prior to operating the crane.

Load charts



7,9 m – 13,7 m
(26 ft – 45 ft)



1360 kg
(3000 lb)



75%



360°



Pounds

Radius in feet	**26 ft Length		45 ft Length	
	#1205	#1207	#1209	#1211
	0° OFFSET	30° OFFSET	0° OFFSET	30° OFFSET
35	5200 (76.9)	—	—	—
40	5200 (75.3)	—	3700 (77.3)	—
45	5200 (73.6)	—	3700 (75.8)	—
50	5200 (71.9)	4800 (77.4)	3700 (74.4)	—
55	5200 (70.1)	4800 (75.6)	3700 (72.9)	—
60	5200 (68.4)	4800 (73.7)	3700 (71.4)	—
65	4230 (66.7)	4800 (71.7)	3700 (69.9)	2500 (77)
70	3370 (64.7)	4240 (69.7)	3700 (68.4)	2500 (75.2)
75	2640 (62.6)	3420 (67.5)	3350 (66.9)	2500 (73.5)
80	2020 (60.5)	2710 (65.2)	2710 (65.4)	2500 (71.7)
85	1480 (58.3)	2100 (62.9)	2160 (63.8)	2500 (69.8)
90	1000 (56.1)	1560 (60.5)	1680 (61.9)	2500 (67.9)
95	590 (53.8)	1080 (58.1)	1260 (59.9)	2180 (65.9)
100	—	660 (55.4)	880 (57.8)	1720 (63.9)
105	—	—	550 (55.6)	1310 (61.7)
110	—	—	—	940 (59.5)
115	—	—	—	600 (57.1)
120	—	—	—	—
Min. boom angle for indicated length (no load)	52°	54°	54°	56°
Max. boom length at 0° boom angle (no load)	64 ft		64 ft	

NOTE: () Boom angles are in degrees. 80094338A

#RCL operating code. Refer to RCL manual for instructions.

**26 ft. capacities are applicable to both 26' fixed and 26' tele extension.

Boom extension capacity notes:

- 26 ft and 45 ft extension lengths may be used for single line lifting service.
- Radii listed are for a fully extended boom with the boom extension erected. For main boom lengths less than fully extended, the rated loads are determined by boom angle. Use only the column which corresponds to the boom extension length and offset for which the machine is configured. For boom angles not shown, use the rating of the next lower boom angle.
Warning: Operation of this machine with heavier loads than the capacities listed is strictly prohibited. Machine tipping with boom extension occurs rapidly and without advance warning.
- Boom angle is the angle above or below horizontal of the longitudinal axis of the boom base section after lifting rated load.
- Capacities listed are with outriggers properly extended and vertical jacks set only.

THIS CHART IS ONLY A GUIDE AND SHOULD NOT BE USED TO OPERATE THE CRANE.

The individual crane's load chart, operating instructions and other instructional plates must be read and understood prior to operating the crane.

Specifications

Superstructure

Boom

9,7 m – 39,0 m (31.7 ft – 128 ft) five-section boom with a maximum tip height of 54,6 m (179 ft). Includes proportional extension via multi-stage hydraulic cylinder and cable operation, four-plate, high-strength steel construction, three-sheave, quick reeve boom nose and Easy-Glide wear pads.

Boom elevation

One (1) double-acting, hydraulic cylinder with integral holding valve with integral pressure transducers provides elevation from -8° to +80°.

Rated Capacity Limiting (RCL) and anti-two-block (ATB) systems

Graphical display capacity limiter and anti-two-block system with audio visual warning and crane function lockout. The graphical display is a 178 mm (7 in) color and polarized screen for real-time display of boom angle, length, radius, tip height, maximum permissible load, load indication and warning of impending overload or anti-two-block condition. Work area definition system (WADS) allowing operator definable non-lockout warning limits for crane operations, and CANbus sensors and hard-wired ATB circuit routed externally to the boom. Outrigger monitoring system (OMS) to sense the configuration of the outriggers and aid the operator in selecting an appropriate setup. On-board setup and diagnostics for RCL sensors allow for improved service and an event recorder to protect your investment.

Crane Control System

Fully integrated RCL and CANbus crane control system for maximum performance. Real-time diagnostics for truck chassis data such as engine regeneration, fuel level, engine coolant, oil pressure, engine RPM and battery voltage. On-board setup and diagnostics for all sensors and control modules allowing for improved service and little need for a laptop or diagnostic cables. Fault codes to quickly identify service needs and event recorder to protect your investment. Automotive grade, fully wire-harnessed 12VDC electrical system using state-of-the-art sealed connectors and control modules. Dual-tone backup and outrigger motion alarm located at rear of machine. LED marker and triple ID lights.

Operator cab and controls

Cab structure: rigid galvanealed steel structure, well insulated, offering optimum operator visibility and comfort. Equipped with tilting cab feature from horizontal to +20°, tinted safety glass, fixed front window with windshield wiper and washer, sliding skylight window with windshield wiper, sliding left side glass door, sliding right side window for ventilation

w/ safety grille, tilting rear window for ventilation, four way adjustable, cushioned seat and armrests with seat belt, diesel-fired warm-water heater with air ducts at operators feet, left side of cab and front dash — standard, hydraulic-powered air conditioner — standard, circulation fan, bubble level, adjustable sun visor, dome light, cup holder, fire extinguisher, load chart binder with tear-proof paper load charts and operator manual.

Armrest control functions are arranged per ASME B30.5: Two single axis electric joystick controllers for swing, boom telescope, main hoist, auxiliary hoist (optional), boom lift, warning horn button, swing park brake switch, hoist rotation indicator, tilt cab up/down, main hoist high/low speed switch, and aux hoist high/low speed switch (optional).

Outrigger controls: front console mounted electronic keypad allowing the operator to activate all horizontal beams and vertical jacks. Pre-selection capabilities to easily activate more than one function for ease of setup.

Foot controls: engine throttle (electronic), dynamic swing brake (electronic), boom telescope (electronic, if equipped with aux hoist option).

Front console controls and indicators for rated capacity limiter display, outriggers, engine ignition key, emergency stop switch, and RCL override keyswitch (momentary). 12VDC power outlet.

Overhead console controls and indicators for heater, A/C and fan speed, windshield wiper and washer, skylight wiper, cab mounted work lights, crane function power, radio remote power.

Removable counterweight

Hydraulically removable counterweight system consisting of (2) vertical double-acting hydraulic cylinders equipped with holding valves to independently raise and lower the desired counterweight slabs. Controls can be activated at both the left and right side of turret near the counterweight for ease of activation during counterweight pin reconfiguration. Counterweight consists of (3) slabs for (4) unique load chart configurations:

- (3) slabs installed on turret: (1) x [3000 lb], (2) x [1250 lb]
- (2) slabs installed on turret: (1) x [3000 lb], (1) x [1250 lb]
- (1) slab installed on turret: (1) x [3000 lb]
- (0) slabs installed on turret: no slabs installed

When not in use, one or all of the slabs can be stowed on top of the front outrigger box. One or all of the slabs can also be removed from the crane by using the crane itself after stowing on front outrigger box first.

Specifications

Slewing

Continuous 360° rotation using (1) low speed, high torque motor with a manually adjustable swing adjustment valve integrated to the hydraulic motor control manifold mounted to a planetary reduction gear. A proportional electronic brake pedal located in the operator cab allows for the dynamic application of the multi-disk swing brake circuit. A separate spring-applied, hydraulic-released brake for disabling rotation can be activated from the left-hand seat armrest. Free-swing functionality is disabled when using the optional crane radio remote control. Maximum rotation speed of 2 RPM.

Hydraulic system

Efficient closed-center, load sense hydraulics system featuring load-sharing technology allowing for smooth multifunction operation of all crane functions. One (1) SAE-C mounted, 130cc axial piston pump for all functions and optimized system performance. Shaft input of 2200 RPM generating 286 lpm (76 gpm) max flow at 320 bar (4600 psi) max operating pressure. 351 L (100 gal) hydraulic reservoir with SAE o-ring connections and integrated butterfly shut-off valve for easy maintenance. SAE o-ring hydraulic fittings and hoses throughout. Boom lift, boom telescope, main and aux hoist(s) and vertical outrigger jacks are all equipped with counterbalance valves for controlled movement and load holding.

Hydraulic oil cooler: standard electric fan, plate and fin style oil cooler mounted in the rear of the superstructure to remove heat from the hydraulic oil under heavy operating conditions.

Electrical system

Automotive grade, fully wire harnessed 12VDC electrical system using state-of-the-art sealed connectors and control modules. Dual-tone backup and outrigger motion alarm located at rear of machine. LED marker and triple ID lights.

Lower

Chassis mounting

Torsion-resistant, high-strength steel sub frame attached using high-strength steel mounting brackets that are welded to the sub-frame and bolted to the truck chassis using Huck® bolts to ensure a secure and maintenance-free connection. Rear bumper under ride protection standard. Fixed boom rest mounted to front outrigger box and fabricated from structural steel.

Outriggers

Out and down style outriggers at both the front and rear with individual control of each horizontal beam extension and vertical jack cylinder. Each outrigger jack is equipped with a 508 mm (20 in) polymeric outrigger float standard. Horizontal beams are non-proportional and can be pinned in (4) different configurations for operation. Front outriggers are angled toward the truck cab, eliminating the need for an SFO. Ground level control stations located at the left and right side for all vertical jacks and only the horizontal beams for each station. Operator cab features an electronic keypad mounted on the front console to control all outrigger functions.

100% span: Front = 7,09 m (23 ft 3 in)

Rear = 7,39 m (24 ft 3 in)

75% span: Front = 5,9 m (19 ft 4 in)

Rear = 6,12 m (20 ft 1 in)

50% span: Front = 4,72 m (15 ft 6 in)

Rear = 4,90 m (16 ft 1 in)

0% span: Front and Rear = 2,39 m (7 ft 10 in)

Outrigger monitoring system for horizontal beam extension is standard. Inverted cylinder rods for vertical outrigger jack cylinders for best protection of chromed rod. Optional single front outrigger (SFO) is available for heavy front axle mounting configurations.

Specifications

Optional items

• Operator aids

- > Five-function wireless radio remote control of approximately 75 m (250 ft) (NB5R)

• Telescopic offsettable jib

- > 7,9 m – 13,7 m (26 ft – 45 ft) telescoping boom extension (side fold for stowing), includes 5,8 m (19 ft) manual pull out section
- > Max tip height of 54,6 m (179 ft)
- > Offsets of 0° and 30°
- > RCL calibration for future jib option

• Fixed offsettable jib

- > 7,9 m (26 ft.) fixed boom extension (side fold for stowing)
- > Max tip height of 49,7 m (162.9 ft)
- > Offsets of 0° and 30°
- > RCL calibration for future jib option

• Auxiliary hoist

- > A second turret-mounted hoist located to the rear of the standard main hoist
- > Standard with rotation-resistant wire rope and round, top-swivel downhaul weight

• Personnel handling platforms

- > (2) person steel, non-insulated, platform options
- > Rotating and yoke-style options
- > Capacities up to 544,3 kg (1200 lb) on main boom and 226,8 kg (500 lb) on jib
- > Platform test weight sets available for each
- > Compliant to ASME B30.23 requirements

• K100™ synthetic rope

- > 18 mm (0.71 in) 137,2 m (450 ft) K100™ synthetic hoist rope (in lieu of standard rope)
- > Available for either main, aux or both hoists
- > 80% lighter than steel wire rope with same available linepull
- > Easy handling/reeving and installation
- > Reduces number of change outs due to mitigation of kinking, birdcaging or damage from diving
- > Corrosion resistant — no rusting, no lubrication requirements

• Hook blocks

- > Single sheave, 18,1 t (20 USt) quick-reeve hook block for 2-3 part reeving [186 kg (410 lb)]
- > Triple sheave, 36,3 t (40 USt) quick-reeve hook block for 4-7 part reeving including auxiliary sheave case assembly (272 kg [600 lb])
- > Five sheave, 49,9 t (55 USt) quick-reeve hook block for 8-10 part reeving including auxiliary sheave case assembly (498 kg [1098 lb])

• Single Front Outrigger

- > 63,5 m (25 in) vertical stroke
- > Available for certain mounting configurations

• Aluminum outrigger floats

- > 610 mm (24 in) aluminum floats in lieu of the standard 500 mm (19.7 in) polymeric floats

Specifications



Main and (optional) auxiliary hoist(s)

Two-speed displacement, bent-axis piston motor driving a planetary gearset and a grooved drum with cable tensioner/follower, drum rotation indicator and last layer and minimum wrap indicators.

Parts of Line	1 part line	2 part line	3 part line	4 part line	5 part line	6 part line	7 part line	8 part line	9 part line	10 part line
Max boom length (ft) at max elevations with stated rigging and load block and ground level	173 (includes 45 ft ext.)	128	102	81	66	55	47	40	35	31.7
Low speed lift (lb)	11,280	22,500	33,750	45,000	56,250	67,500	78,750	90,000	100,000	110,000
High speed lift (lb)	5000	10,000	15,000	20,000	25,000	30,000	35,000	40,000	45,000	50,000

Line Pulls and Reeving Information			
Hoists	Cable specs.	Permissible line pulls	Nominal cable length
Main	16 mm (5/8 in) Dyform 34 LR Rotation Resistant (non-rotating) Min. Breaking Strength 56,420 lb	11,280 lb*	450 ft
Main and Auxiliary	16 mm (5/8 in) 6x19 Class EEIPS, IWRC Min. Breaking Strength 45,400 lb	11,280 lb*	450 ft
Main and Auxiliary	18 mm Synthetic K-100™ Hoist Rope (ISO) Min. Breaking Strength 63,700 lb	12,740 lb*	463 ft

The approximate weight of 5/8 in wire rope is 1.0 lb/ft.

The approximate weight of 18 mm synthetic rope is 0.16 lb/ft.

*With certain boom and hoist tackle combinations, the allowable line pull may be limited by hoist performance. Refer to Hoist Performance table for lift planning to ensure adequate hoist performance on drum rope layer required.

Hoist Performance				
Wire rope layer	Hoist line pulls		Drum capacity (ft)	
	Two speed hoist		Layer	Total
	Low	High		
	Available lb	Available lb		
1	15,000	7516	82	82
2	13,529	6765	92	174
3	12,299	6150	101	275
4	11,275	5637	110	385
5	10,407	5204	119	504

*Refer to Line Pulls and Reeving Information table for max. lifting capacity of wire rope.

Synthetic rope layer height may vary and may reduce available line pull per layer.



























Weight Reductions for Load Handling Devices	
Auxiliary boom nose	32.2 kg (71 lb)
Hook blocks and headache balls	
55 USt, 5-sheave (14 in sheave) CE	498.0 kg (1098 lb)+
40 USt, 3-sheave (12 in sheave)	272.2 kg (600 lb)+
20 USt, 1-sheave	181.4 kg (400 lb)+
7 USt overhaul ball	163.7 kg (250 lb)+

+ Refer to rating plate for actual weight

When lifting over boom extension, deduct total weight of all load handling devices reeved over main boom nose directly from boom extension capacity.

NOTE: All load handling devices and boom attachments are considered part of the load and suitable allowances MUST BE MADE for their combined weights. Weights are for Manitowoc furnished equipment.

Symbols glossary

 Axles	 Drive	 Heavy duty jib	 Radius
 Boom	 Electrical system	 Hoist	 Rotation
 Boom elevation	 Engine	 Hook block	 Speed
 Boom extension	 Extension	 Hydraulic system	 Steering
 Boom length	 Frame	 Insert	 Suspension
 Boom nose	 Fuel tank capacity	 Lights	 Swing
 Brakes	 Gear	 Oil	 Tires
 Operators station	 Grade	 Outrigger controls	 Transmission
 Counterweight	 Height (no max)	 Outriggers	

To learn more about this model, call 414-764-9200 or visit giuffre.com today!

Notes

GIUFFRE.COM

42



AVAILABLE AT:

GIUFFRE.COM

GIUFFRE BROS CRANES INC.

6635 SOUTH 13TH ST. - MILWAUKEE, WI 53221
414-764-9200 • 877-321-3710

To learn more about this model, call 414-764-9200 or visit giuffre.com today!

Notes

GIUFFRE.COM

National Crane NTC55

43



AVAILABLE AT:

GIUFFRE.COM

GIUFFRE BROS CRANES INC.

6635 SOUTH 13TH ST. - MILWAUKEE, WI 53221
414-764-9200 • 877-321-3710

To learn more about this model, call 414-764-9200 or visit giuffre.com today!



Manitowoc Cranes

Regional headquarters

Americas

Manitowoc, Wisconsin, USA

Tel: +1 920 684 6621

Fax: +1 920 683 6277

Shady Grove, Pennsylvania, USA

Tel: +1 717 597 8121

Fax: +1 717 597 4062

Europe, Middle East, Africa

Dardilly, France - TOWERS

Tel: +33 (0)4 72 18 20 20

Fax: +33 (0)4 72 18 20 00

Wilhelmshaven, Germany - MOBILE

Tel: +49 (0) 4421 294 0

Fax: +49 (0) 4421 294 4301

China

Shanghai, China

Tel: +86 21 6457 0066

Fax: +86 21 6457 4955

Greater Asia-Pacific

Singapore

Tel: +65 6264 1188

Fax: +65 6862 4040

Dubai, UAE

Tel: +971 4 8862677

Fax: +971 4 8862678/79



This document is non-contractual. Constant improvement and engineering progress make it necessary that we reserve the right to make specification, equipment, and price changes without notice. Illustrations shown may include optional equipment and accessories and may not include all standard equipment.

©2017 The Manitowoc Company, Inc.
Form No. NTC55 PG
Part No. 17-006/ZM/0217

www.manitowoc.com



AVAILABLE AT:

GIUFFRE.COM

GIUFFRE BROS CRANES INC.

6635 SOUTH 13TH ST. - MILWAUKEE, WI 53221
414-764-9200 • 877-321-3710